



BlastLogic

---

## BlastLogic Tablet

Help Documentation



# BlastLogic Tablet

Help Documentation

# Copyright

© 2025 Maptek Pty Limited

Maptek, Vulcan, I-Site, BlastLogic, Eureka, PerfectDig, Evolution, Sentry, CaveLogic, PointStudio, DomainMCF, GeologyCore, MaterialMRT, PointModeller, GeoSpatial Manager, VisionV2X and the stylised Maptek M are registered and unregistered trademarks of Maptek Pty Limited; Maptek Computación Chile Ltda; Maptek Computación Chile Ltda, Sucursal Perú; Maptek S de RL de CV; Maptek Informática do Brasil Ltda and KRJA Systems, Inc. Registered marks are registered in one or more of the following countries: Australia, Brazil, Canada, Chile, China, Greece, India, Indonesia, Mexico, Peru, Russia, South Africa, Spain, the United Kingdom, and the United States of America.

ALL RIGHTS RESERVED. No part of this manual shall be reproduced, stored in a retrieval system, or transmitted by any means—electronic, mechanical, photocopying, recording, or otherwise—without written permission from Maptek™.

No patent liability is assumed with respect to the use of the information contained herein.

Although every precaution has been taken in the preparation of this manual, the publisher and author(s) assume no responsibility for errors or omissions. Neither is any liability assumed for damages resulting from the use of the information contained herein.

# Trademarks

Due to the nature of the material, some hardware and software products are mentioned by name. The companies that manufacture the products claim many of these product names as trademarks. It is not the intention of Maptek™ to claim these names or trademarks as their own.

# Revision History

Issue	Date	Team
2025.1	August 2025	Technical Publications Team, Adelaide
2025	March 2025	Technical Publications Team, Adelaide
3.3	October 2024	Technical Publications Team, Adelaide
3.2	December 2023	Technical Publications Team, Adelaide
3.1	November 2021	BlastLogic Development Team, Adelaide
3.0	July 2021	IDT Team, Adelaide
2.9	May 2021	IDT Team, Adelaide
2.8	September 2020	BlastLogic Development Team, Adelaide
2.7	June 2020	BlastLogic Development Team, Adelaide
2.6	October 2019	BlastLogic Development Team, Adelaide
2.5	June 2019	BlastLogic Development Team, Adelaide
2.4	February 2019	BlastLogic Development Team, Adelaide
2.3	November 2018	BlastLogic Development Team, Adelaide
2.2	June 2018	BlastLogic Development Team, Adelaide
2.1	August 2017	BlastLogic Development Team, Adelaide
2.0	July 2015	BlastLogic Development Team, Adelaide
1.0	June 2015	BlastLogic Technical Team, Brisbane First release

# About Maptek Documents

The following conventions are typically used in training manuals and guides:

Example	Description
<b>Design &gt; Object Edit</b>	Text in bold are commands or options selected from a menu, panel, or button.
<b>Top Down</b> or <b>Bottom-Up</b> design method	Text in bold is also used for emphasis, specific terms, tab names, column names, panel group names etc.
<LEVEL>_SURVEY_POINTS>	File names or extensions, variables, formulas, text entry, layers, triangulations, databases, scripts, macros, and data such as displayed in the <b>Report</b> window, are in code font.

 **Tip:** Designates a hint such as an effective use of an option.

 **Note:** Designates a point to draw attention to; an informational comment.

 **Important:** Designates an alert to draw particular attention to.

# Contents |

---

<b>About Maptek Documents</b> .....	<b>ii</b>
<b>1. Overview</b> .....	<b>1</b>
<b>2. Getting Started</b> .....	<b>2</b>
2.1 Adding a site and server .....	2
2.2 Claiming a licence .....	4
2.3 Starting work .....	6
<b>3. Network Connectivity</b> .....	<b>7</b>
3.1 No field wireless network .....	7
3.2 Field wireless connectivity .....	8
<b>4. Synchronising Data</b> .....	<b>9</b>
4.1 Synchronisation modes .....	9
4.1.1 <i>Automatic synchronisation</i> .....	9
4.1.2 <i>Manual synchronisation</i> .....	9
4.2 Upload queue .....	10
<b>5. GNSS Status</b> .....	<b>11</b>
5.1 GNSS tab .....	11
5.1.1 <i>Windows Location</i> .....	11
5.1.2 <i>Serial Port</i> .....	13
5.2 Disabled tab .....	13
5.3 Simulate tab .....	14
<b>6. Common Functionality</b> .....	<b>15</b>
6.1 Options panel .....	16
6.2 Entering comments .....	19
6.3 Viewing comments .....	20
6.4 Entering and viewing anomalies .....	21
6.5 Manual hole sequencing .....	23
6.6 Automatic hole sequencing .....	24
6.7 Products in sequence .....	25

---

6.8 Instructions tab .....	26
<b>7. Entering Drilling Data .....</b>	<b>27</b>
7.1 Getting started .....	27
7.2 Hole status in drilling module .....	29
7.3 Entering drilling data for a drillhole .....	30
7.4 Redrilling a hole .....	34
7.5 Creating an ad hoc hole .....	35
<b>8. Entering Dip Data .....</b>	<b>36</b>
8.1 Getting started .....	36
8.2 Hole status in Dipping module .....	38
8.3 Table view .....	38
8.4 Map view .....	41
<b>9. Entering Backfill Data .....</b>	<b>43</b>
9.1 Getting started .....	43
9.2 Hole status in backfilling module .....	45
9.3 List view .....	46
9.4 Map view .....	47
<b>10. Entering Charge Data .....</b>	<b>49</b>
10.1 Getting started .....	49
10.2 Charge data entry views .....	51
10.2.1 Preview .....	52
10.2.2 Open Cup view .....	54
10.2.3 Map view .....	55
10.3 Entering dip data to update charge plans .....	58
10.4 Loading decks from the plan .....	61
10.5 Entering a top-up deck .....	63
10.6 Loading ad hoc decks .....	65
10.7 Loading ad hoc primers .....	67
<b>11. Viewing Charging Activity .....</b>	<b>68</b>
11.1 Viewing charging activity .....	68
11.1.1 Charging Summary tab .....	69
11.1.2 Decks tab .....	69

---

11.1.3 Initiating Explosives tab .....	70
<b>12. Blasts .....</b>	<b>71</b>
12.1 Getting started .....	71
12.2 Hole status in Blasts module .....	72
12.3 Summary view .....	73
12.3.1 Hole status information .....	73
12.3.2 Planned and actual hole charging .....	74
12.3.3 Blast Products Report .....	74
12.3.4 Custom View Hole Counts .....	74
12.4 Blast status .....	75
12.4.1 Marking a blast as fired .....	75
12.4.2 Reverting a blast to active state .....	76
12.5 Map view .....	77
<b>13. Inventory Data .....</b>	<b>78</b>
13.1 Inventory data .....	78
13.1.1 Stock Levels .....	78
13.1.2 History .....	79
13.1.3 Edit Inventory .....	81
13.1.4 Bulk Usage .....	83
<b>14. Editable Parameters and Properties .....</b>	<b>85</b>
<b>15. Troubleshooting .....</b>	<b>88</b>
15.1 Restoring default screen layout on the BlastLogic Tablet .....	88
15.2 Hiding tablet keyboard .....	88

# 1. Overview |

BlastLogic is a software system for managing the drill and blast process of open-cut mines.

This manual is a help documentation for the BlastLogic Tablet application. The Tablet interfaces with the BlastLogic Server to allow you to view blast information, and enter drilling, dipping, backfilling, charging, and inventory data.

# 2. Getting Started |

Before using the BlastLogic Tablet, you must connect and synchronise it with a BlastLogic Server.

**Note:** Once the Tablet has been synchronised, the site, server, and login credentials will be remembered.

## 2.1 Adding a site and server

**Note:** Ensure the Tablet can connect to the BlastLogic Server before starting.

1. Open the BlastLogic Tablet application.
2. Tap **Add Site**.

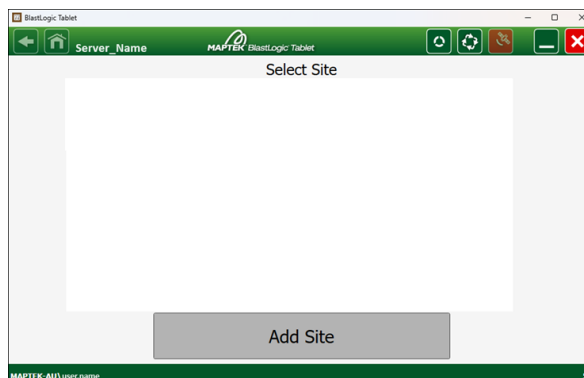

Figure 2-1 Add Site screen

**Note:** You can add a site only when you have not claimed a licence. If you want to add a site when your licence is still valid, you need to return it first.

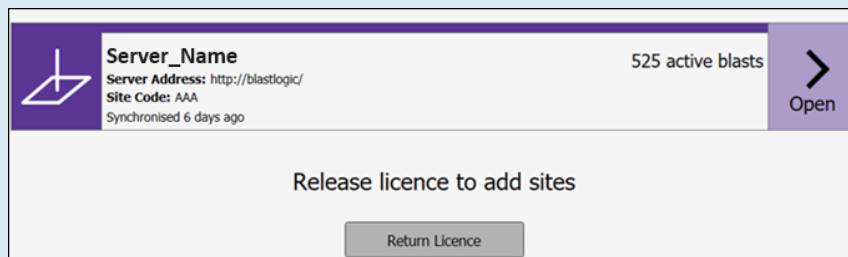
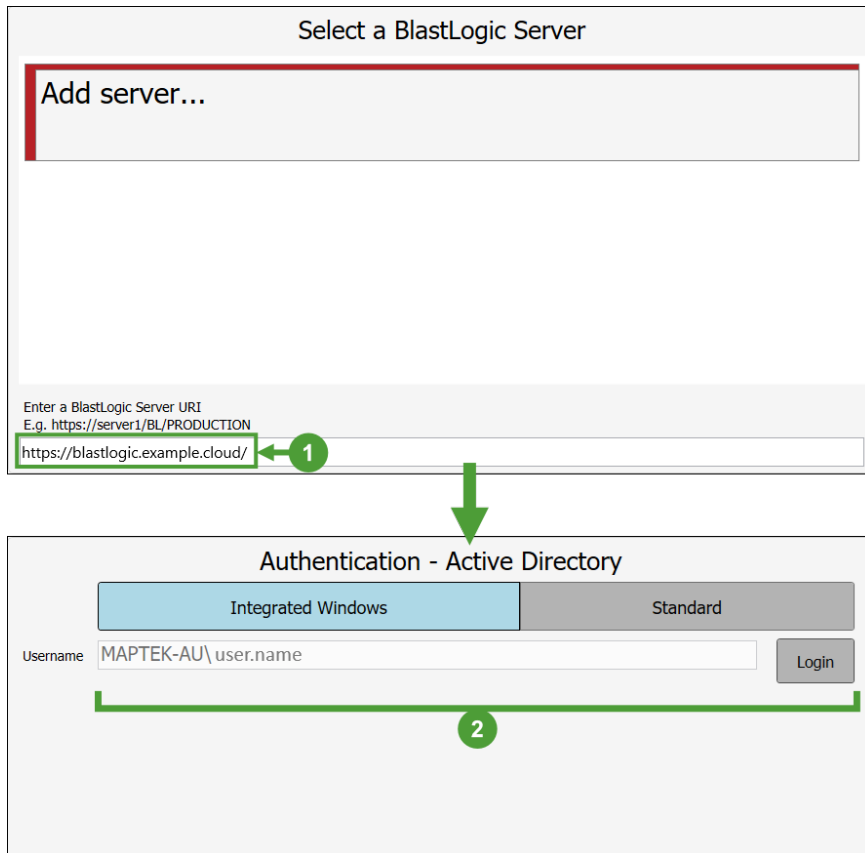

Figure 2-2 Return Licence screen

For more information on licences, see [2.2 Claiming a licence](#) on page 4.

3. Tap **Add server...** and enter server URI. If the server is successfully detected, the login panel will appear.



**Figure 2-3** Login panel after identifying the BlastLogic Server

4. Select **Integrated Windows** or **Standard** type and enter the **Username**.
5. Tap **Login**.

**Note:** A generic user account is typically created for all Tablet users rather than using individual accounts.

6. Tap **Open** for the appropriate site.

**Note:** There might be old archived and test sites also available on the BlastLogic Server, so be sure to select the correct site.

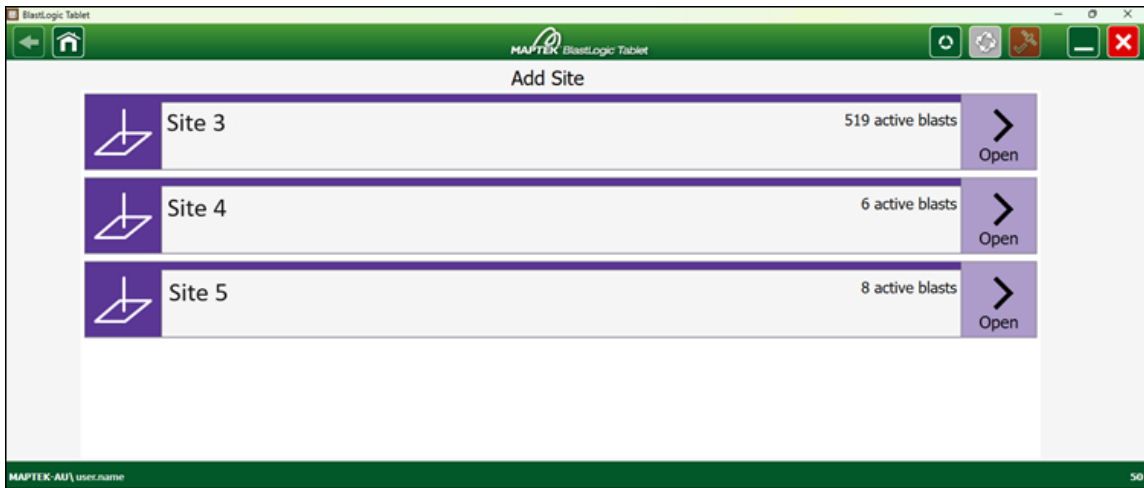



Figure 2-4 Site selection screen

7. Wait for the  (Synchronisation Status) button on the top right-hand corner of the screen to stop rotating. This will indicate that all currently active sheets have been uploaded on the Tablet.

## 2.2 Claiming a licence

To claim a licence, tap the  button on the top right-hand corner of the screen. The **Licence Period** screen will appear. Select the required period and tap **Yes** if you want your licence to be renewed automatically. Finish by tapping **Claim Licence**.

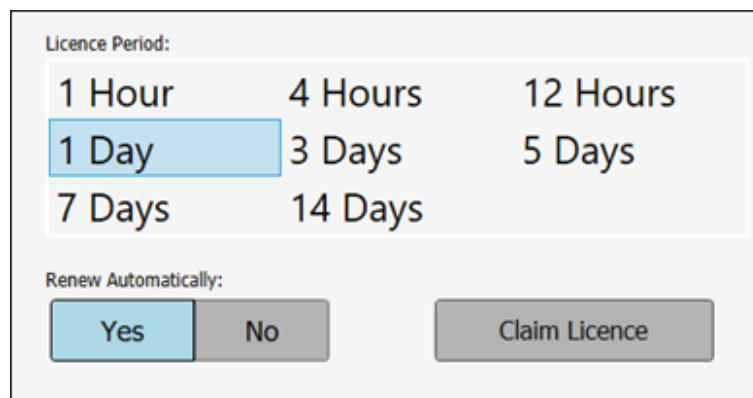



Figure 2-5 Claim Licence screen

You can check the status of your licence or return it any time by tapping the  button.

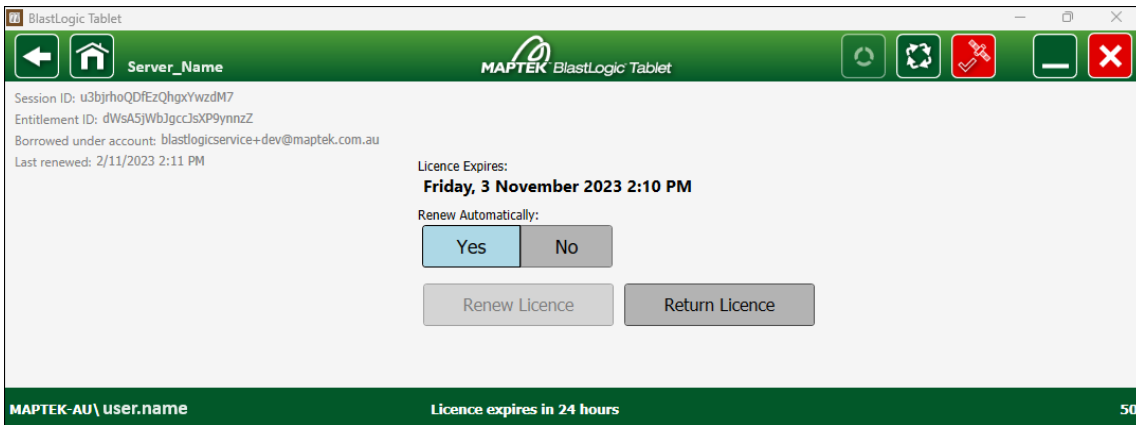

Figure 2-6 Licence status and management screen

When you tap the **Return Licence** button, a pop-up window asking you to confirm your selection will appear. Tap **Yes** to continue.

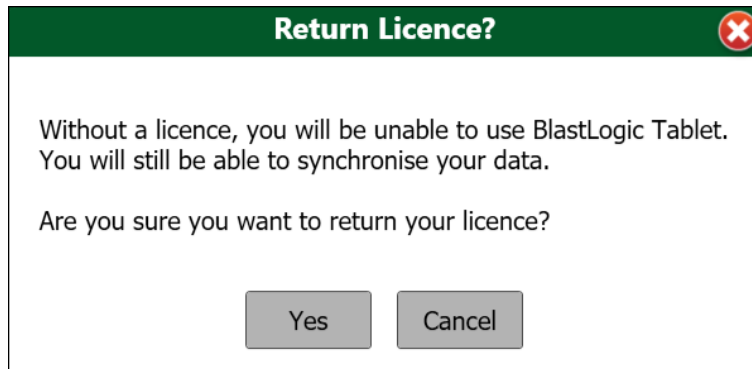

Figure 2-7 Return licence confirmation pop-up window

## 2.3 Starting work

If you previously closed or terminated the Tablet application, and your licence still has not expired, the program will open the most recent site that has been set.

**Note:** You will not need network connection if you previously synchronised your Tablet.

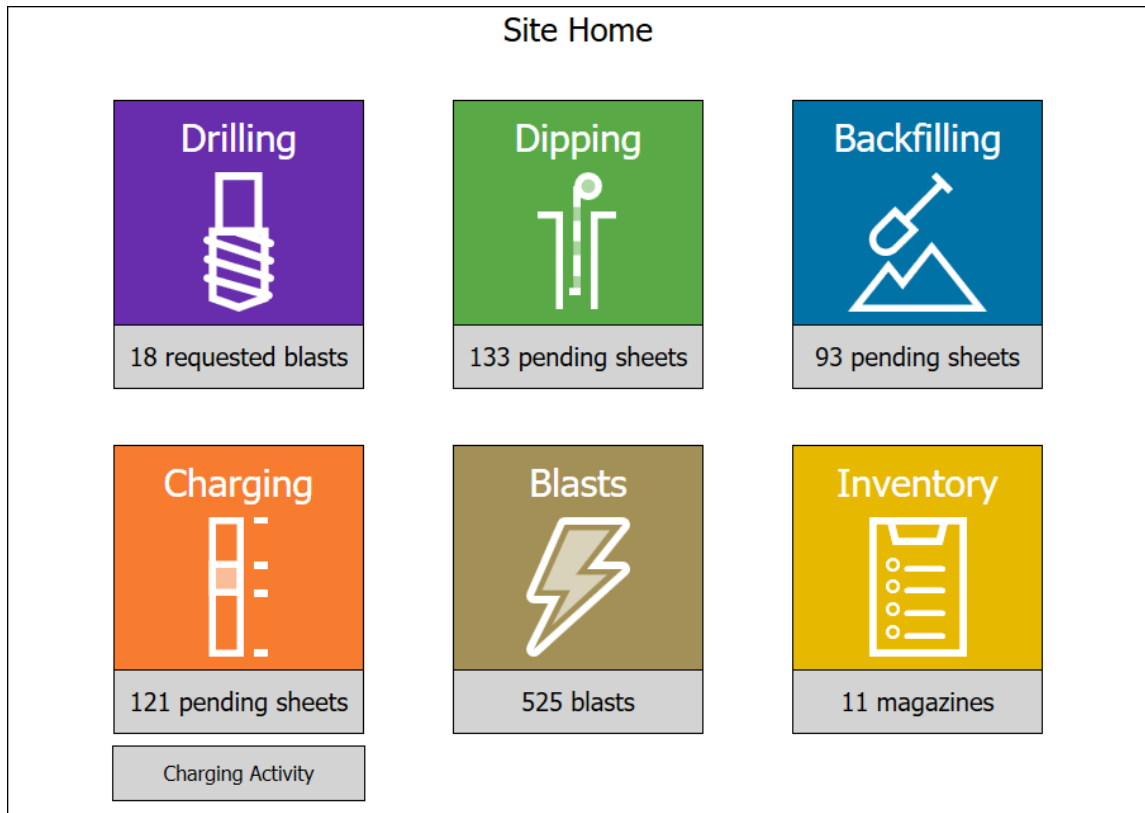



Figure 2-8 Site Home: BlastLogic module selection screen

**Note:** If you closed the Tablet application after terminating your licence, or if your licence has expired, the **Licence Period** screen will appear first. Obtain a licence according to the steps shown in [2.2 Claiming a licence](#) on page 4.

- ▶ Tap **Drilling** or **Blasts** to view or add blasts.
- ▶ Tap the **Dipping**, **Backfilling**, or **Charging** button to view available and recently completed sheets.
- ▶ Tap the **Inventory** button to view or add inventory activity.

# 3. Network Connectivity |

When sufficient network connectivity is available, the BlastLogic Tablet will automatically synchronise all incomplete sheets containing holes in an active blast, provided you have set the synchronisation mode to **Automatic**. See [4 Synchronising Data](#) on page 9 for more information.

 **Tip:** Blasts and their sheets will be available on the BlastLogic Tablet if the blast is 'active' or if the blast was fired before 7 days ago, or if the blast was loaded with product at least 7 days ago. To remove a sheet, you can cancel all pending entries on this sheet, or mark the blast as **Fired, Suspended, or Abandoned**.

## 3.1 No field wireless network

Once you synchronise your BlastLogic Tablet with the BlastLogic Server, you can use it offline to capture data in the field.

All entries will be saved locally on the Tablet until it connects to the Server and uploads the entered data.

- You can use multiple tablets simultaneously to enter data in the same sheet. However, you will only be able to view the data that was entered on the corresponding tablet.
- To avoid synchronisation conflicts, do not enter the same data on multiple tablets for the same holes.

 **Tip**

Follow these steps to use the BlastLogic Tablets without network connectivity:

1. Synchronise the Tablets in the office.
2. Verify if synchronisation has been successful and if any new sheets were retrieved.
3. Move to the field and use the Tablet offline to collect data.
4. Return the tablets to the office at the end of the shift to upload data to the Server.
5. Tap the **Sync** button to upload and clear the queue.

## 3.2 Field wireless connectivity

The BlastLogic Tablets will automatically download the new and updated sheets and entries, as well as upload newly entered data to the Server periodically, according to the configuration. Once the Tablets are synchronised, each Tablet user will be able to view data entered by other users. Charge plans will be updated according to the latest drilling, dipping, or backfill data, whether it be entered on the same or other tablet.

# 4. Synchronising Data |

The data you enter using the BlastLogic Tablet application needs to be synchronised with the BlastLogic Server to be shared with other BlastLogic Desktop and Tablet users.

To enter synchronisation settings, tap  (Synchronisation Status) at the top of your screen.

## 4.1 Synchronisation modes

The BlastLogic Tablet supports two synchronisation modes:

- **Automatic** synchronisation
- **Manual** synchronisation

### 4.1.1 Automatic synchronisation

When you set the synchronisation mode to **Automatic**, entries are automatically synchronised with the Server at the set frequency. When the BlastLogic Tablet has insufficient network connectivity with the Server, data will wait in the queue until the Tablet can connect to the Server.

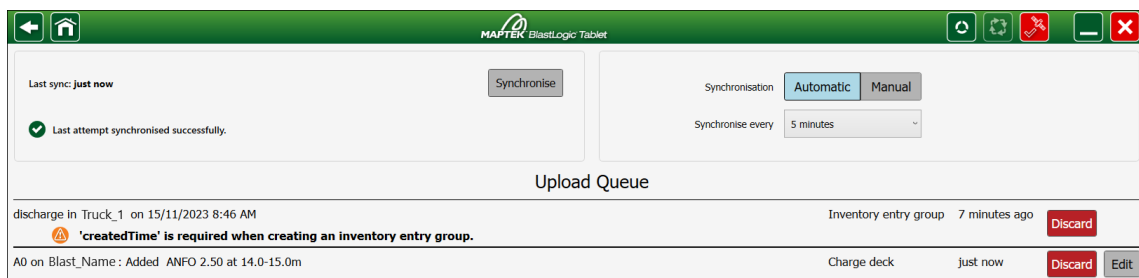

Figure 4-1 Automatic synchronisation setting

### 4.1.2 Manual synchronisation

When you set the synchronisation mode to **Manual**, the BlastLogic Tablet will only synchronise with the BlastLogic Server when you tap the **Synchronise** button.

Manual synchronisation can be useful during training to avoid fake data entries being synchronised, or if the same data has been entered on multiple tablets and conflicts result. It is also useful when there is no network connectivity, as it prevents wasting system resources on futile synchronisation attempts.

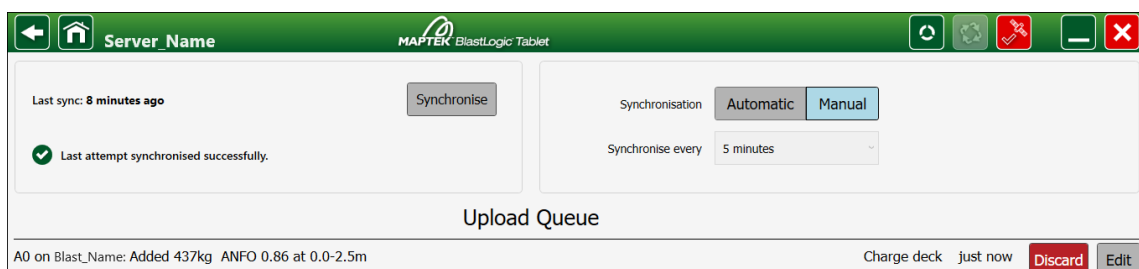

Figure 4-2 Manual synchronisation setting

## 4.2 Upload queue

The entries that were added in the period between sync operations will appear on the list with the **Edit** and **Discard** buttons, which means you can still change or undo them before the synchronisation attempt takes place.

The entries that could not be synchronised due to an error, data conflict, or incorrect settings will appear on the list with the **Discard** button, allowing you to undo the attempted changes.

Once discarded, the data is removed from the BlastLogic Tablet and will not be synchronised with the BlastLogic Server.

When synchronised, the queue is empty, and the panel informs that the last synchronisation attempt has been successful.

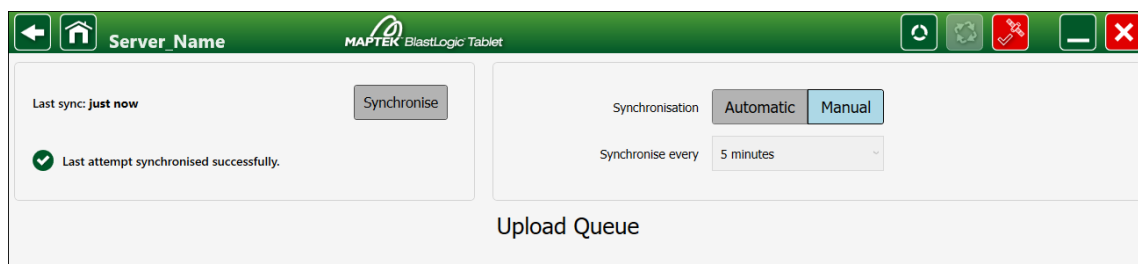

Figure 4-3 Empty upload queue

The synchronised entries will appear on the BlastLogic Desktop and other BlastLogic Tablet devices, provided they have also synchronised with the BlastLogic Server.

# 5. GNSS Status |

The **GNSS Status** module allows you to obtain detailed information on your current location (geographic coordinates, site coordinates, etc.).

To enter the module, tap the  (GNSS Status) button at the top of your screen.



Figure 5-1 GNSS Status button on the menu bar

The **GNSS Status** module consists of the following tabs:

- **GNSS**: Provides information on the geographic location based on the Windows Location API driver or serial port connection.
- **Disabled**: Disables location data transfer.
- **Simulate**: Simulates the site's GNSS position based on the currently open sheet (blast).

## 5.1 GNSS tab

The **GNSS** tab provides you with the information on the geographic location based on Windows Sensor API Location Service or the serial port connection.

### 5.1.1 Windows Location

You can install the Windows Location API driver by following these steps:

1. Install the Tablet software.
2. Go to the `C:\Program Files\Maptek\BlastLogic Tablet [version number] \GPS_Serial_Sensor_Driver\64bit` and select **GssdInst.exe** to install.
3. Proceed with the **GssdInst.exe** file installation.

To allow the BlastLogic Tablet application to receive information on your device's location, go to **Settings > Privacy & security > Location**, and select **Let desktop apps access your location**.

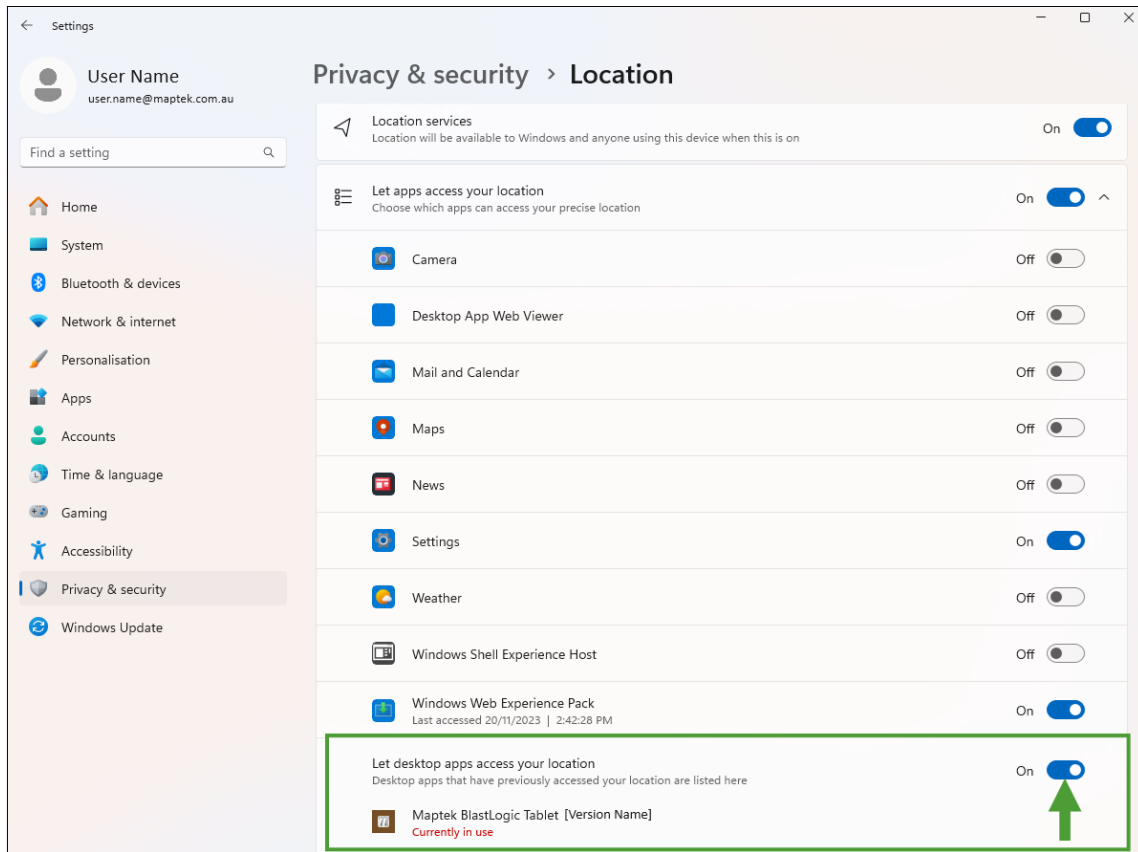

Figure 5-2 Enabling the BlastLogic Tablet to receive location information

Once you provide your desktop apps permission to access the device’s location, the GNSS tab will show the current position based on Windows Sensor API Location Service.

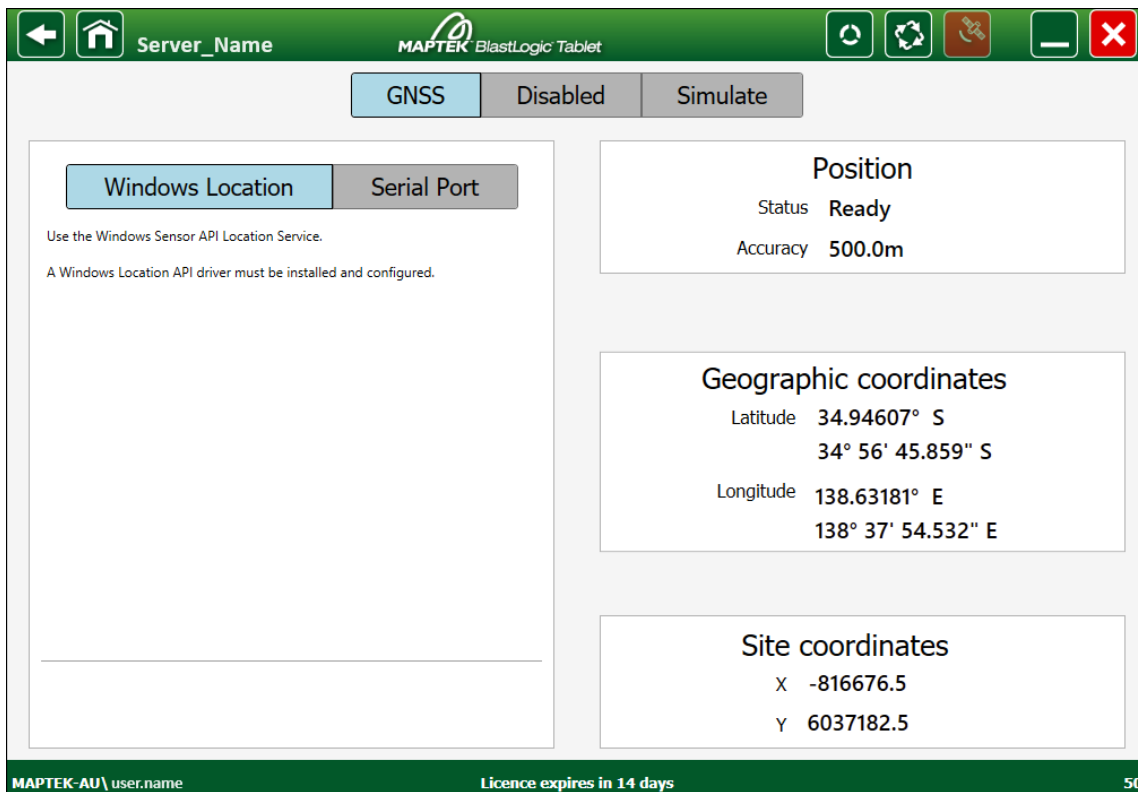

Figure 5-3 Current position based on Windows Sensor API Location Service (example)

**Note:** Contact your IT department in case of any problems with enabling the Windows location services, as these settings might be disabled internally by organisational policy.

## 5.1.2 Serial Port

You can connect to GNSS directly via a serial port source.

After connecting your device to the serial port, select the appropriate configuration from the **Serial Port** and **Baud Rate** drop-down menus.

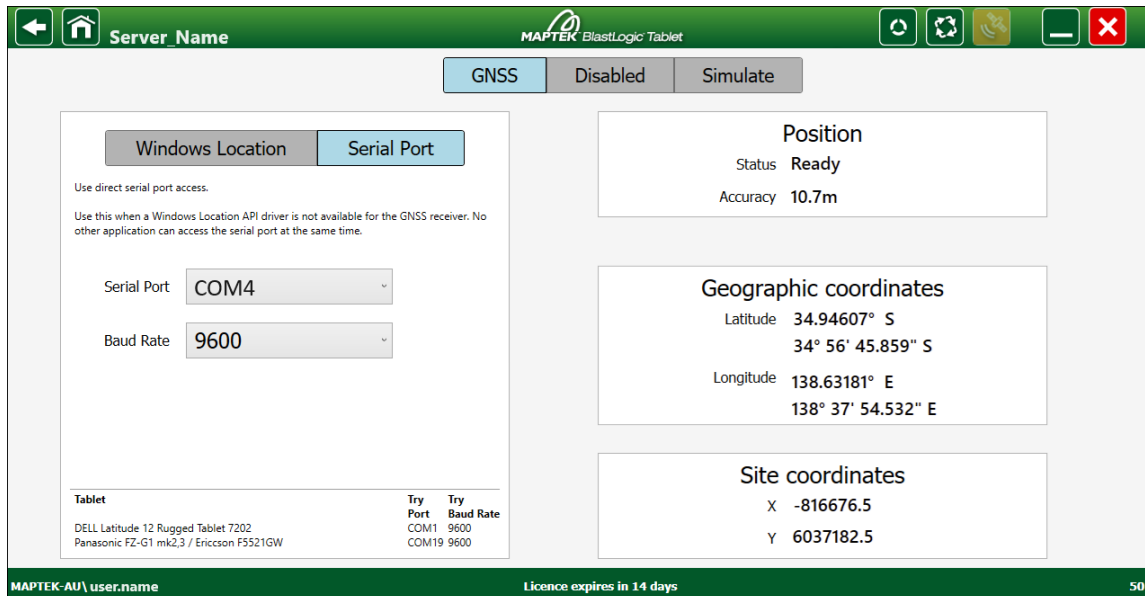

Figure 5-4 Current position based on serial port connection (example)

## 5.2 Disabled tab

When you enter the **Disabled** tab, the Tablet will stop tracking its location and the GNSS data will not be available. To maintain this state, leave the GNSS Status screen when the **Disabled** tab is open.

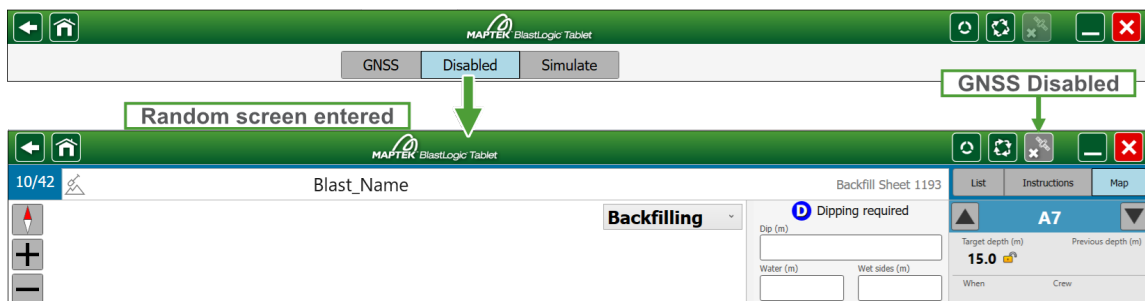





Figure 5-5 GNSS button when location tracking is disabled

The GNSS Status button will become grey (  ) to indicate that the function has been disabled. To activate location tracking again, tap the  button and tap the **GNSS** tab.

## 5.3 Simulate tab

The **Simulate** tab simulates the site's GNSS position based on the currently open sheet (blast).

<p><b>No sheet (blast) open</b></p>	<p>The button indicates inactive state: </p> <div data-bbox="582 573 1327 1144"> <p><b>Simulate</b></p> <p><b>Position</b>                  Status <b>No data - open a sheet</b>                  Accuracy -</p> <p><b>Geographic coordinates</b>                  Latitude                    Longitude</p> <p><b>Site coordinates</b>                  X -                  Y -</p> </div>
<p><b>Location information based on the currently open sheet</b></p>	<p>The button indicates active state: </p> <div data-bbox="582 1263 1327 1816"> <p><b>Simulate</b></p> <p><b>Position</b>                  Status <b>Ready</b>                  Accuracy <b>3.2m</b></p> <p><b>Geographic coordinates</b>                  Latitude <b>85.53211° S</b>                                    <b>85° 31' 55.590" S</b>                  Longitude <b>44.84172° E</b>                                    <b>44° 50' 30.204" E</b></p> <p><b>Site coordinates</b>                  X <b>555.0</b>                  Y <b>555.0</b></p> </div>

# 6. Common Functionality |



The **Drilling**, **Dipping**, **Backfilling**, **Charging**, and **Blasts** modules share common elements and functionality. The task bar, as featured below, contains the following buttons:



Figure 6-1 Buttons included in the task bar

1. <b>Find</b>	Finds a hole by its name.
2. <b>Select closest</b>	Selects the closest hole using GPS position.
3. <b>Centre selected</b>	Centres the map on the selected hole.
4. <b>i</b>	Shows comments related to the selected hole.
5. <b>?</b>	Shows a list of symbols used for that module.
6. <b>Sequence holes...</b>	Changes the sequence of holes.

The following functions, placed above the task bar, allow you to further adjust your view:

	Centres the map displayed on the Tablet based on the GPS location.
	Allows you to change the sizes of holes and their labels in the view, display or hide the abandoned holes, and select the nearest holes using GPS. See <a href="#">6.1 Options panel</a> on the next page for more information.

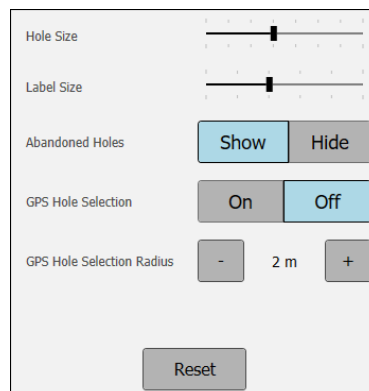

Figure 6-2 Settings in the **Options** panel (example)

In addition to these features, the following functionality is offered across all modules:

- Adding comments to a hole. Once you add comments to a hole, you will be able to view them across all modules.
- Manual sequencing that can be performed across modules.
- Viewing loaded decks, planned, and loaded primers in the **Map** view.

## 6.1 Options panel

The **Options** panel in the **Map** view of the **Drilling**, **Dipping**, **Backfilling**, **Charging**, and **Blasts** modules allows you to change the size of holes and their labels in the view, display or hide the abandoned holes, and select the nearest holes using GPS.

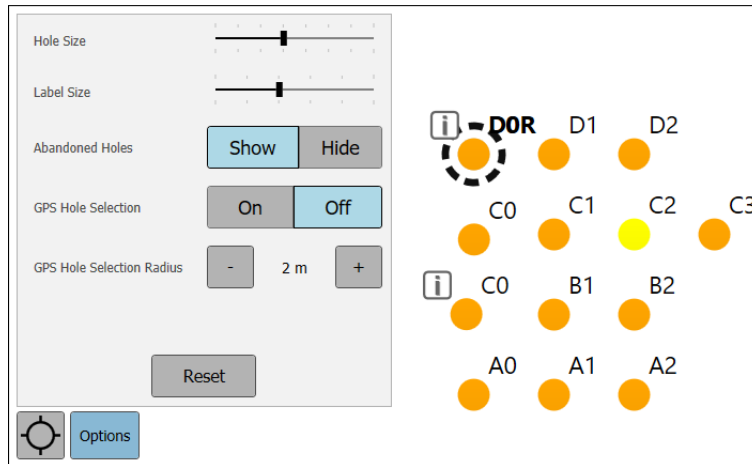

Figure 6-3 Options panel (default settings)

See the table below for more information on each setting provided within the **Options** panel.

**Hole Size**

Use the slider to set the required hole size in your view.

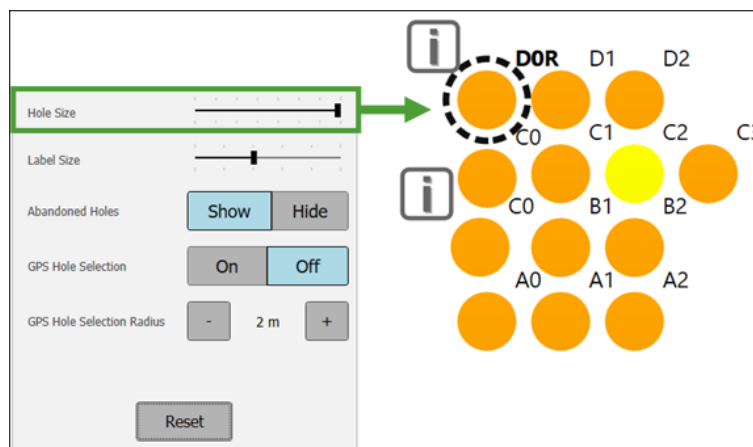

Figure 6-4 Hole size setting (example)

**Note:** All holes will always have the same size set.

---

**Label Size**

Use the slider to set the required size of hole labels in your view.

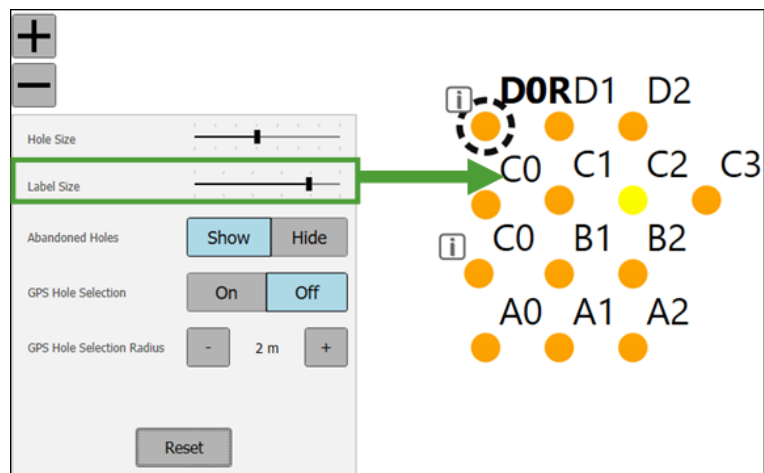

**Figure 6-5** Label size setting (example)

**Note:** All holes will always have the same label size set.

---

**Abandoned Holes**

Select whether to hide or show the abandoned holes in your view.

---

**GPS Hole Selection  
and  
GPS Hole Selection Radius**

Enable the **GPS Hole Selection** for the BlastLogic Tablet to automatically select the nearest hole. Input the required value in the **GPS Hole Selection Radius** field to specify the area around holes that the Tablet will abide by when it determines which hole is the closest to you.

**Note:** To indicate that this mode is enabled, a dashed line running from your current GPS position to the nearest hole will be displayed.

**Tip:** You can also enable this mode with the **F3** key.

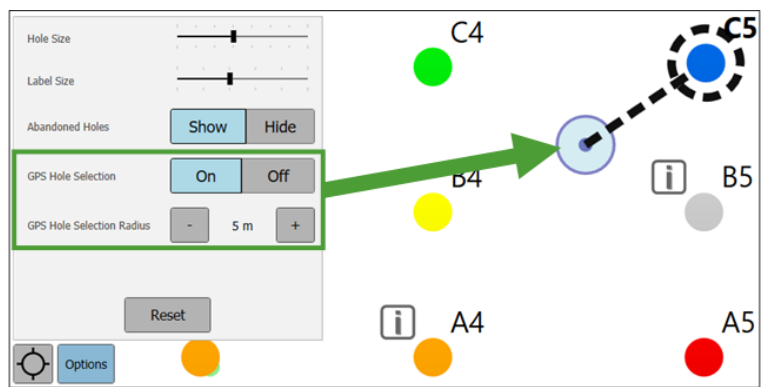

**Figure 6-6** The nearest hole determined based on the GPS position (example)

**Note:** The **GPS Hole Selection** mode will not operate when the GPS reports accuracy over 15 meters.

**Note:** This mode will be turned off when you select a hole manually.

**Reset** Reset your view to the default settings.

## 6.2 Entering comments

You can enter comments for each hole in your blast.

Follow these steps to enter a new comment:

1. Tap on a hole to select it and tap the  (Edit using the comment editor) button on the right part of your screen.

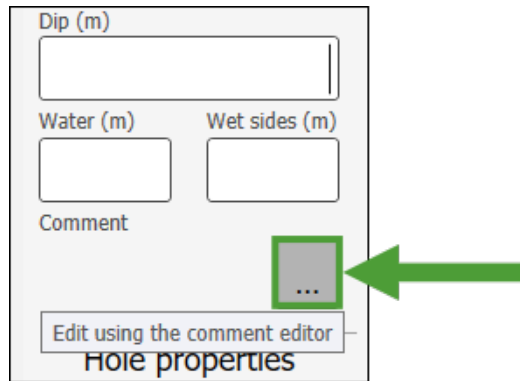

Figure 6-7 The button for entering comments

2. Use the Windows on-screen keyboard to enter your comment.

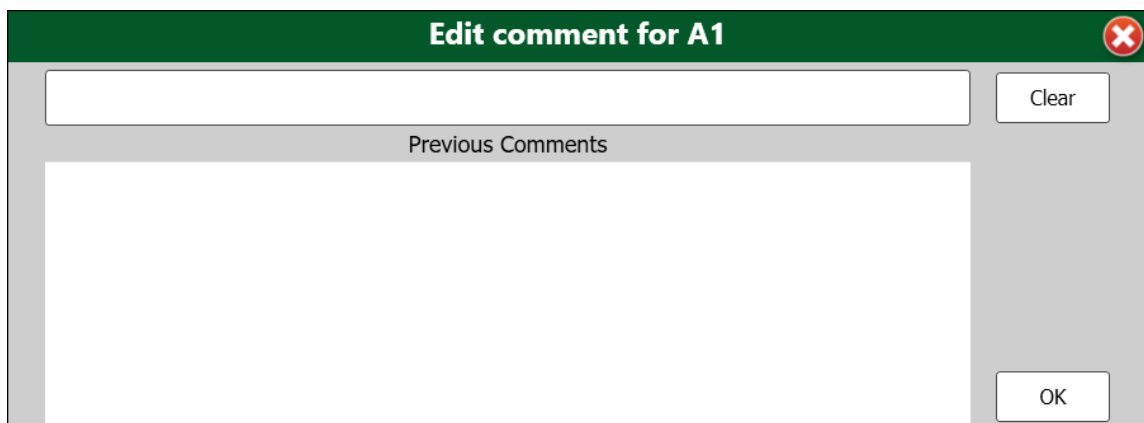



Figure 6-8 Comment entering field

3. Tap **OK** to save your comment.

 **Note:** You can add only one comment to each hole.

 **Tip:** Press the **A2** button on the bottom of the tablet to bring up the keyboard.

When you add a new comment, the previously entered comment will be moved to the **Previous Comments** list. This list is available for all holes in your blast.

To use a previously entered comment:

1. Tap on a hole to select it, then click the  (Edit using the comment editor) button on the right part of your screen.
2. Select a comment from the **Previous Comments** list.

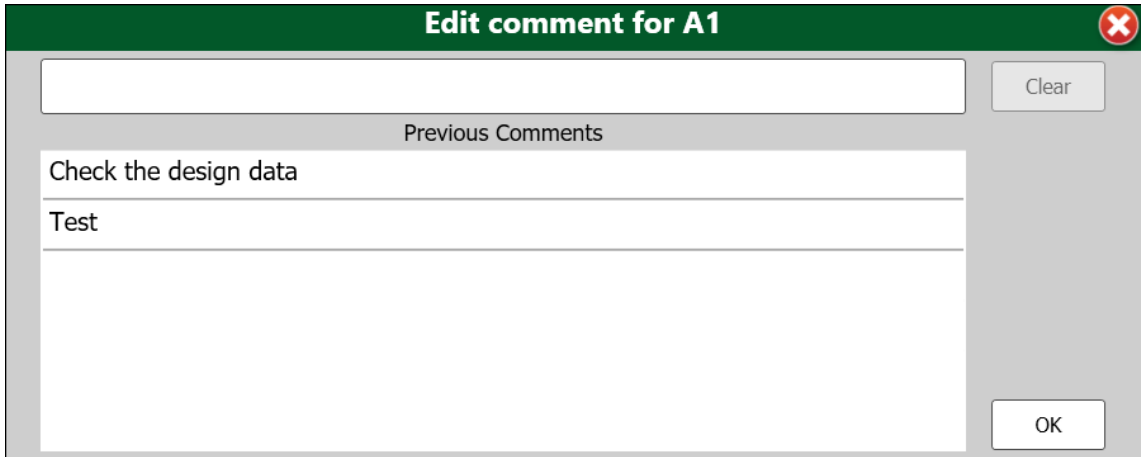



Figure 6-9 Previous comments list

3. Tap **OK**.

## 6.3 Viewing comments

To view comments associated with a hole, select a hole either on the list or map view and then tap  in the task bar at the bottom of the screen.

The panel will list the comments associated with the hole, and their events (for example, dipping), as well as the times when they were recorded.

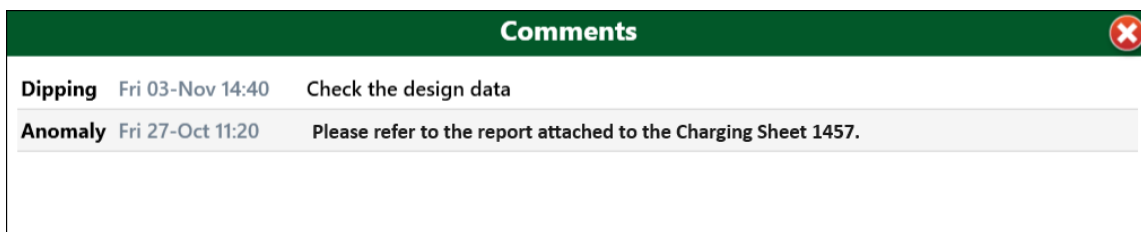

Figure 6-10 Recorded comments (example)

The preview of your comment for the selected hole will also be visible in the **Comment field** on the right side of your screen.

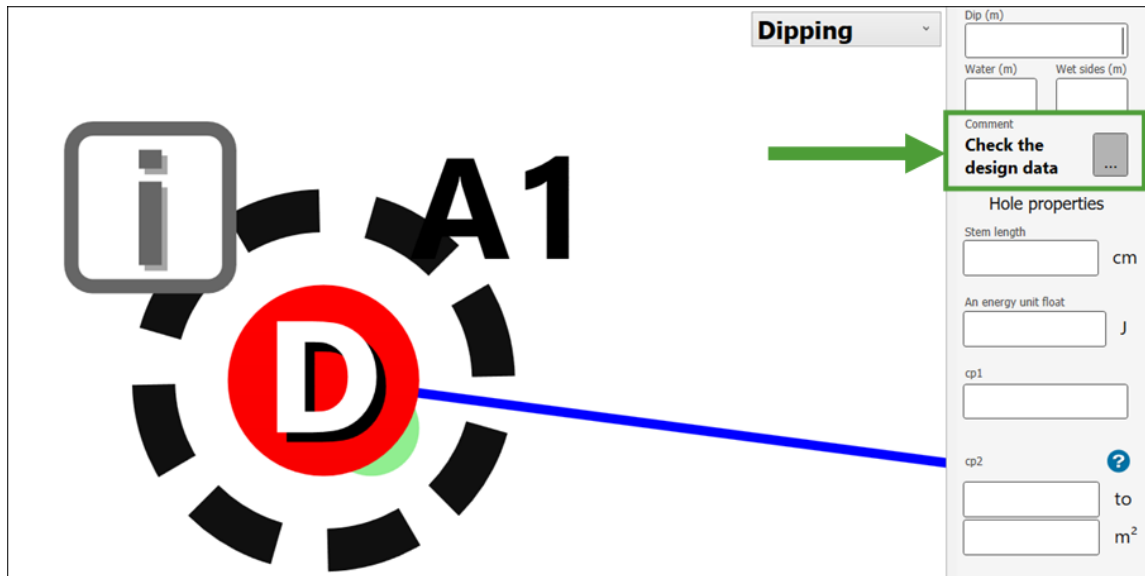

Figure 6-11 Preview of the entered comment

## 6.4 Entering and viewing anomalies

You can record anomalies for each hole in your blast.

Follow these steps to enter information on an anomaly:

1. Tap on a hole to select it in the **Table** or **Map** view, and tap the **Anomalies** button on the right side of your screen.
2. Use the Windows on-screen keyboard to enter your comment and tap **Save**.

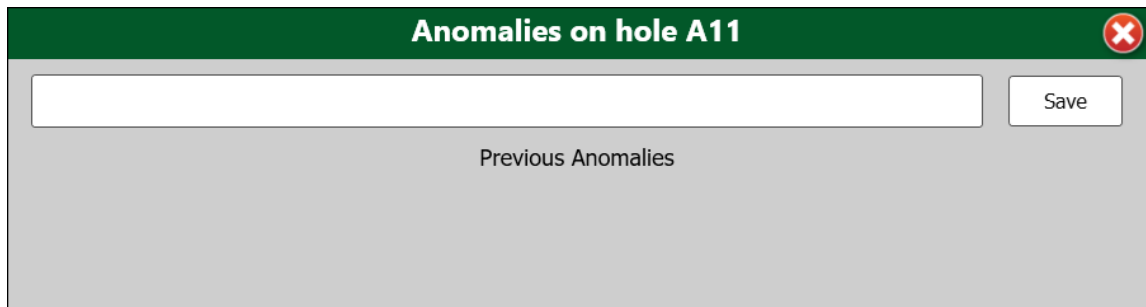

Figure 6-12 Anomaly entry field

The history of the recorded anomalies will be loaded when you tap the **Anomalies** button.

To delete an anomaly, tap the **Delete** button and then confirm your selection by tapping **Delete** again.

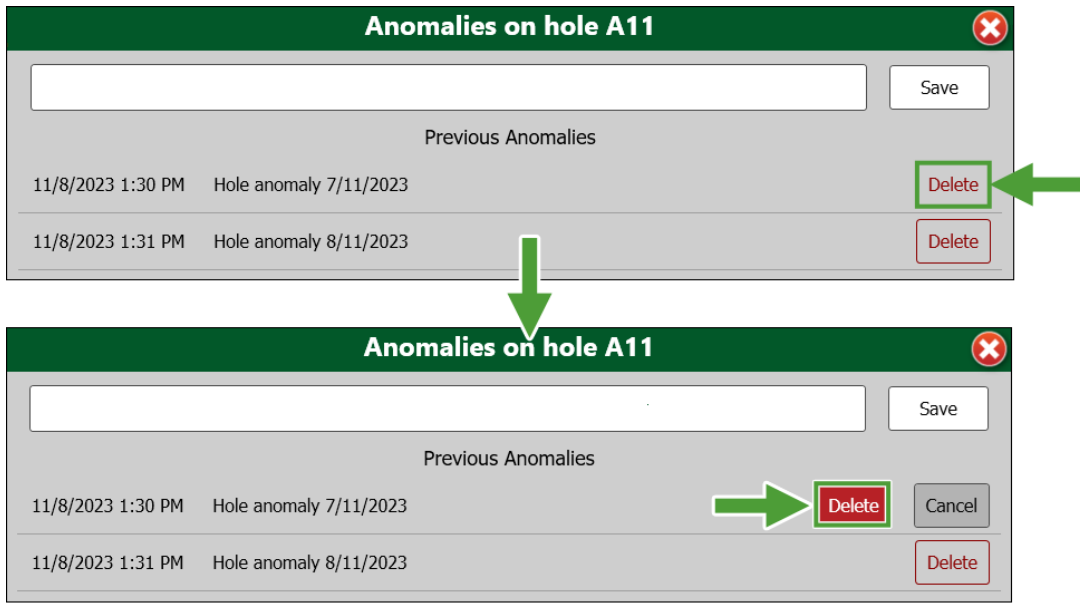



Figure 6-13 Anomaly entry field

If other comments have been saved for the hole for which you have entered an anomaly, the information on the anomaly will be displayed together with them when you tap the  button.

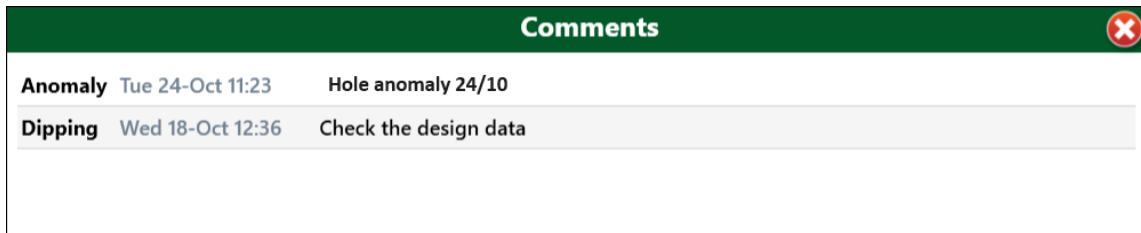

Figure 6-14 Anomaly entry field

For more information on applying and viewing comments, see [Entering comments](#) and [Viewing comments](#).

## 6.5 Manual hole sequencing

You can create a custom hole sequence by following the steps below:

1. Select **Map** view.
2. Tap the **Sequence holes** button in the task bar.
3. Tap the **Manual** button.
4. Select between the **Hole by Hole** and **Start to End** options to create a sequence. Start your sequence by clicking on a hole that you want to be the first in order and, while holding the left mouse button, drag your mouse up to the hole that you want to be the last one. The hole at which you release the mouse will be the last one in your sequence.

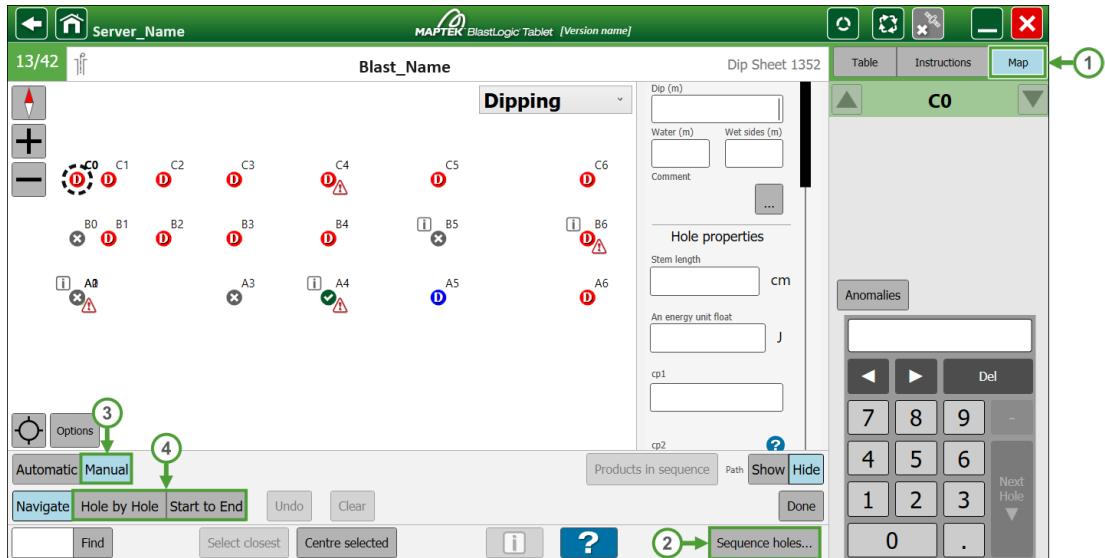
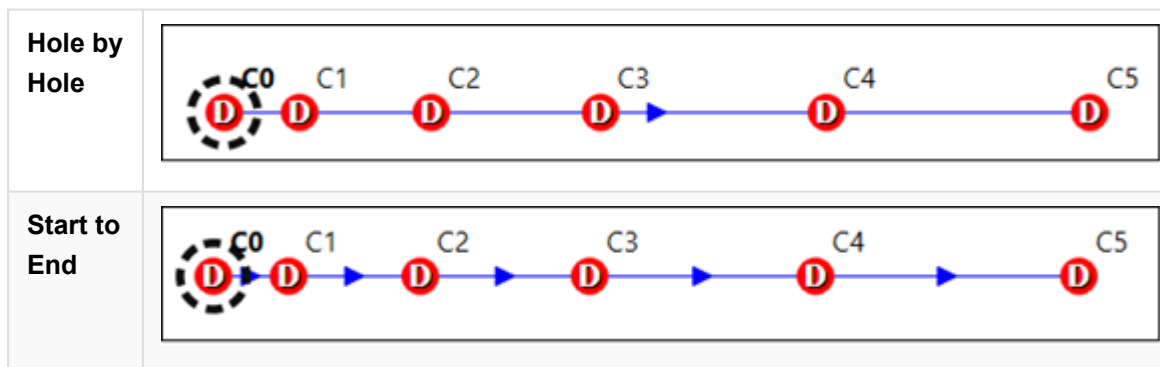

Figure 6-15 Creating a custom hole sequence (manual hole sequencing)

The **Hole by Hole** option will connect the first and the last hole that you choose, whereas the **Start to End** will create an arrow between every consecutive hole from start to finish.



- ▶ Tap the **Clear** button to clear the sequence path.
- ▶ Tap the **Undo** button to cancel the last performed operation.

## 6.6 Automatic hole sequencing

You can specify the sequence of holes in your blast by selecting a predefined sequence pattern.

Follow these steps to apply the automated hole sequencing:

1. Select **Map** view.
2. Tap the **Sequence holes** button in the taskbar.
3. Tap the **Automatic** button.
4. Select one of the four sequence patterns provided.

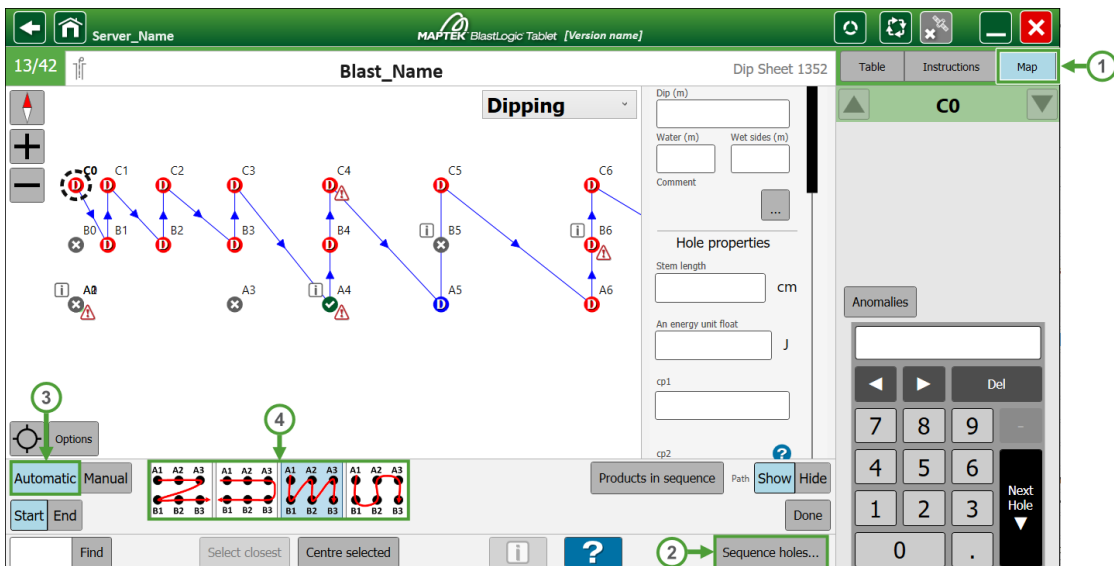
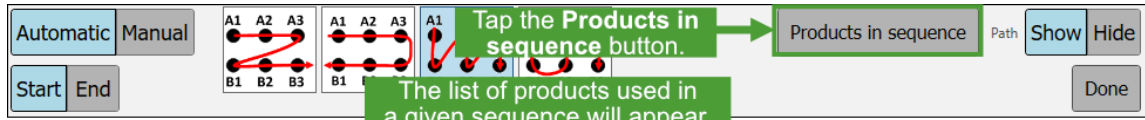

Figure 6-16 Setting automatic hole sequencing

## 6.7 Products in sequence

The **Products in sequence** button allows you to view the products used for the holes in the given sequence. The amount of the grouped products is shown for the **Planned** and **Loaded** data.



Blast Products in Sequence				
	Planned	Loaded	Difference	
Down Hole Detonators	10	11	-1	
DHD Family	0	3	-3	
5ms	0	3	-3	
15.00m lead	0	2	-2	
5.00m lead	0	1	-1	
DigiShot Detonator	4	2	2	
DigiShot Detonator 15.00m	3	1	2	
DigiShot Detonator 46.00m	0	1	-1	
DigiShot Detonator 9.00m	1	0	1	
Electnet	2	3	-1	
Electnet 12.00m	1	2	-1	
Electnet 16.00m	1	1	0	
Test family 1ms 25.00m	4	2	2	
uni tronic 600 20.00m	0	1	-1	
Boosters	0	2	-2	
African Booster	0	2	-2	
Bulk Explosives	5,056 kg	100,004,375 kg	-99,999,319 kg	
ANFO	2,049 kg	3,219 kg	-1,170 kg	
ANFO 0.86	0 kg	2,090 kg	-2,090 kg	
ANFO 1.00	393 kg	393 kg	0 kg	
ANFO 2.50	1,657 kg	736 kg	921 kg	
Dessert 1.00	712 kg	344 kg	368 kg	
Dummy Product 1.12	2,295 kg	100,000,812 kg	-99,998,517 kg	

Figure 6-17 A list of products used in a sequence (example)

For information on the products used in a given blast, see [Blasts](#) module.

## 6.8 Instructions tab

The **Instructions** tab is available in the **Drilling**, **Dipping**, **Backfilling**, and **Charging** modules and reflects the information that you have entered when creating a corresponding sheet in the BlastLogic Desktop application.

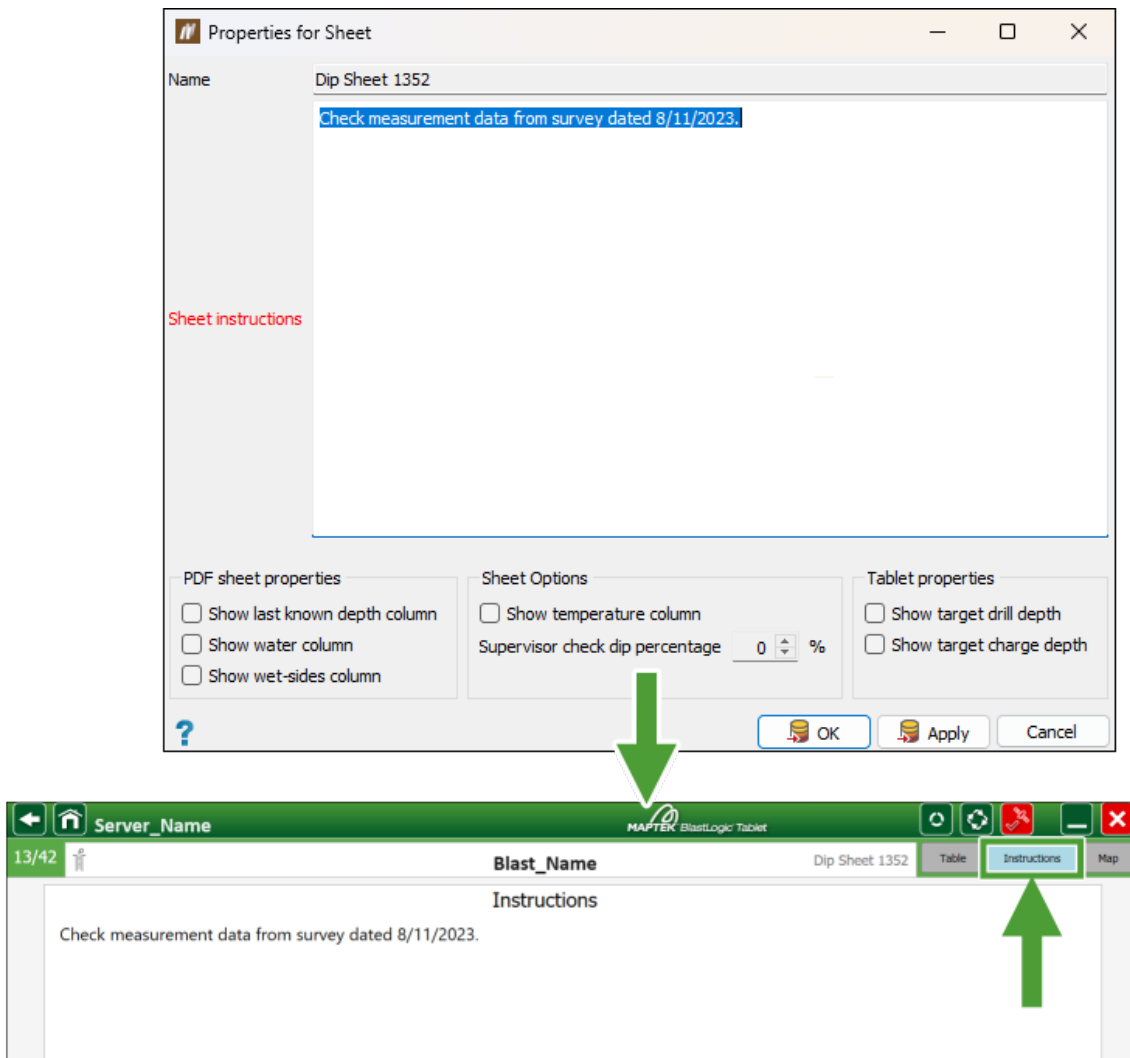

**Figure 6-18** Sheet instructions recorded in the BlastLogic Desktop application reflected on the BlastLogic Tablet (example)

# 7. Entering Drilling Data I

Use the **Drilling** module to enter drilling data.

## 7.1 Getting started

To load the **Drilling** module, go to the **Site Home** page and tap the **Drilling** button.

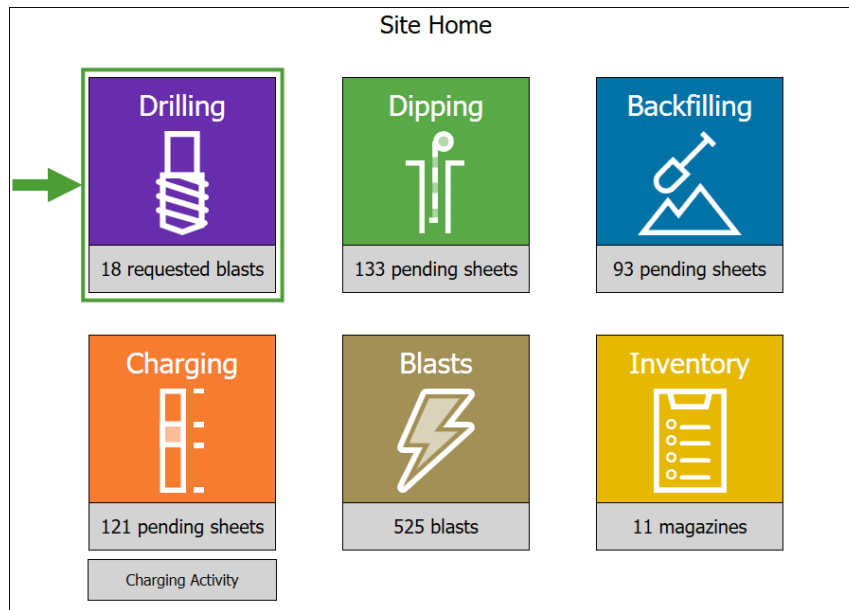

**Figure 7-1** Entering the **Drilling** module from the **Site Home** screen

A list of blasts saved in your database will appear. The blasts will be grouped into the following tabs:

- **Drilling requested**
- **Active blasts**
- **Recently fired blasts**

Navigate to the blast you would like to enter data for and tap **Open**.

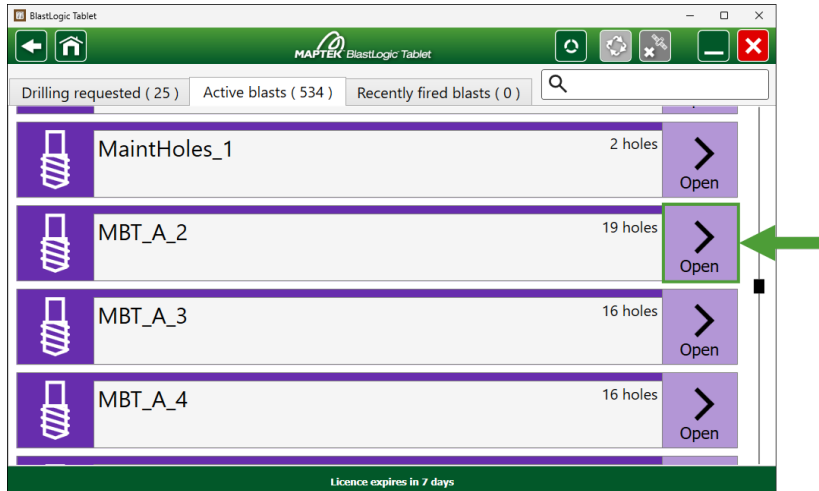

Figure 7-2 Selecting a blast to open in the Drilling module

**Tip**

Use the search field to filter the list of displayed blasts. As you enter the characters constituting the required phrase into the search field, the BlastLogic Tablet will dynamically show the blasts that include matches, even if your phrase is part of a longer word.

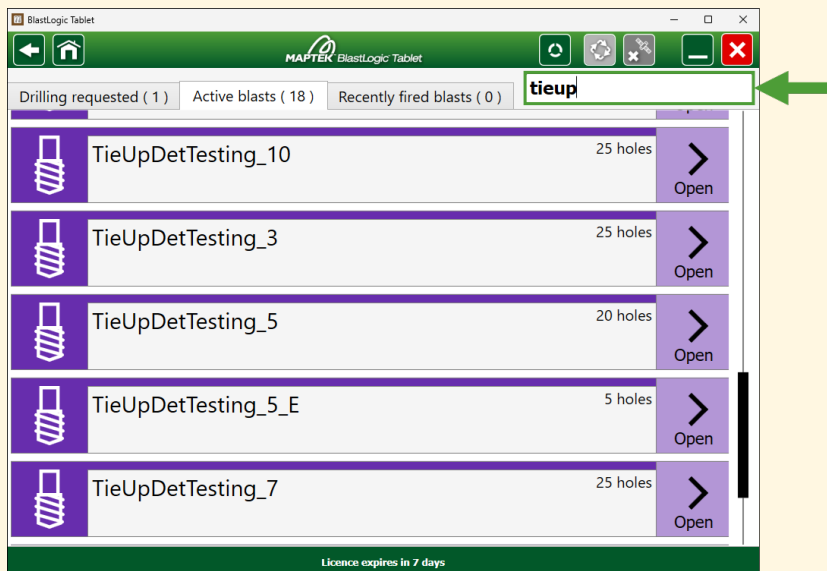

Figure 7-3 Using the search field to navigate to the required blast

Select the drill machine and operator, then tap **Continue**.

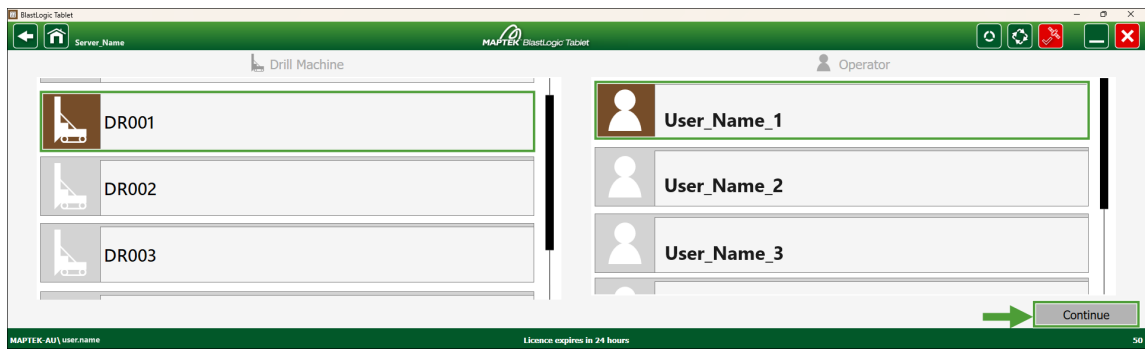

Figure 7-4 Entering the **Drilling** module after selecting a drill machine and operator

## 7.2 Hole status in drilling module

The status of each hole in your view is indicated by an icon.

You can check the meaning of each icon on the pop-up window that appears when you tap the  button on your task bar.



Figure 7-5 Hole status in the **Drilling** module

## 7.3 Entering drilling data for a drillhole

Follow these steps to enter drill data against a blast:

1. Select a hole in the **List** view and enter data for each hole property.

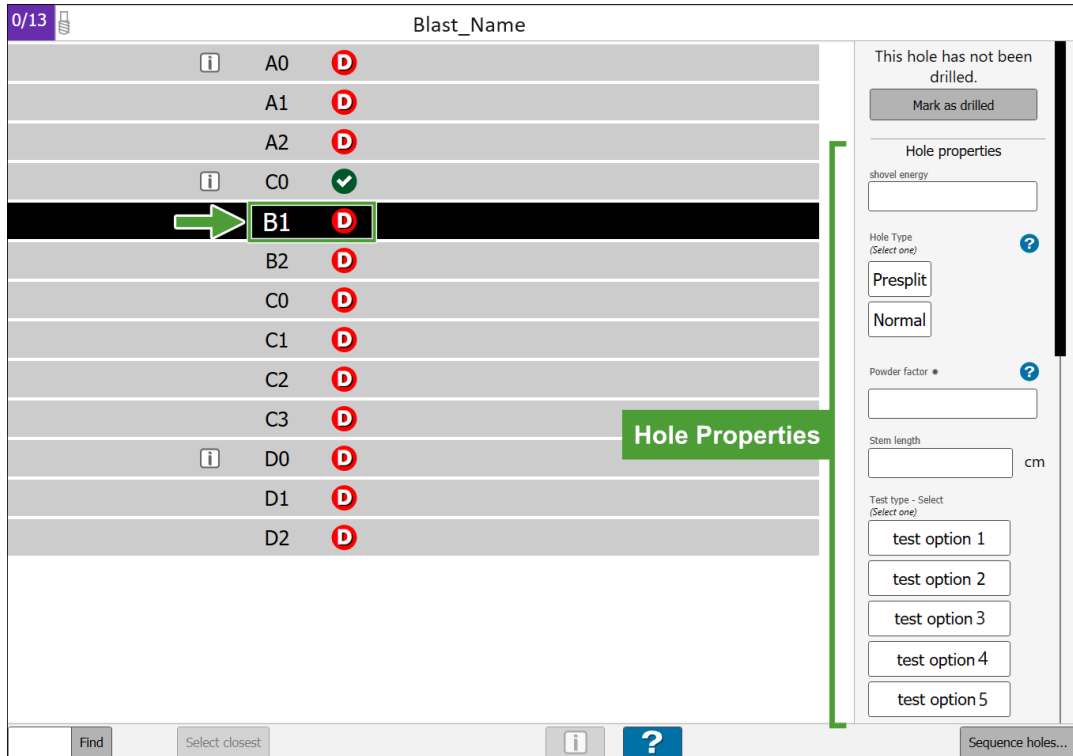
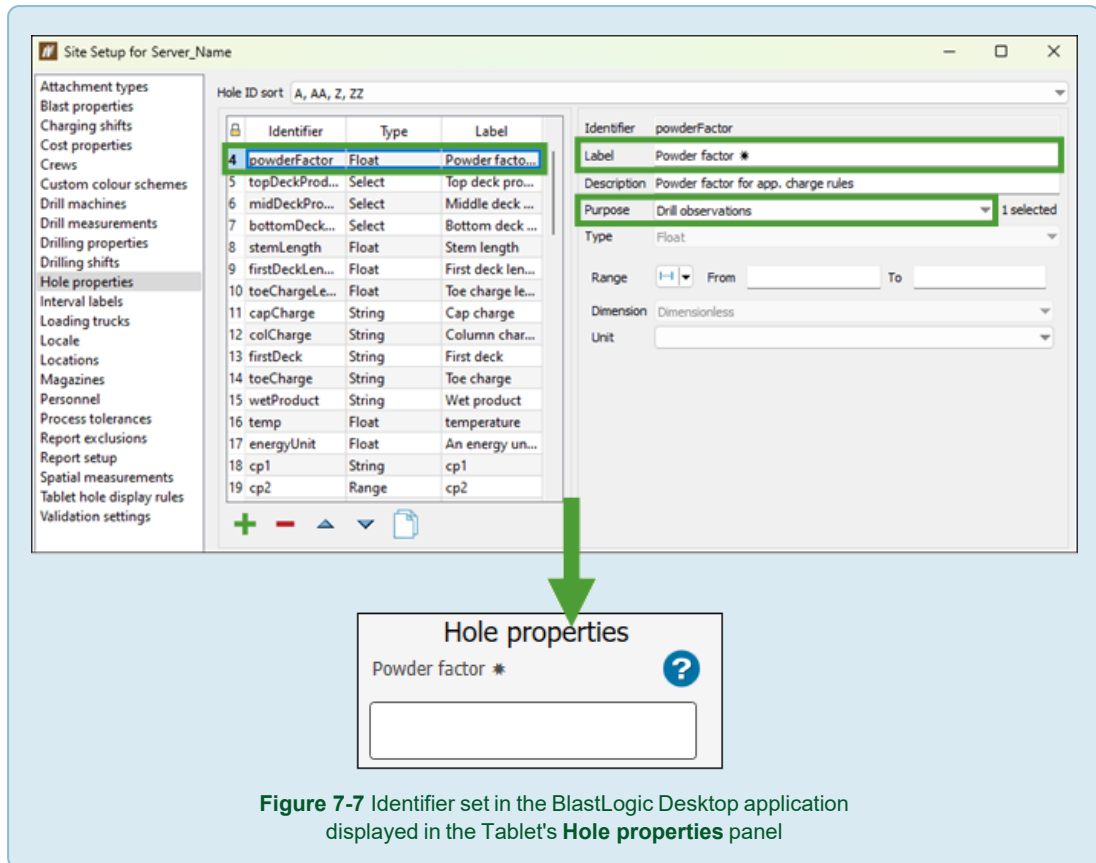

Figure 7-6 Entering hole properties for a selected hole

**Note**

The **Hole properties** shown in the **Drilling** module correspond to the identifiers you have set in the **Hole properties** panel in the BlastLogic Desktop application (**Home** ribbon > **Setup** group > **Site** > **Hole properties**).



**Figure 7-7** Identifier set in the BlastLogic Desktop application displayed in the Tablet's **Hole properties** panel

2. Tap **Mark as drilled** to mark the hole drilled. This will open a new tab panel on the right side of the list.

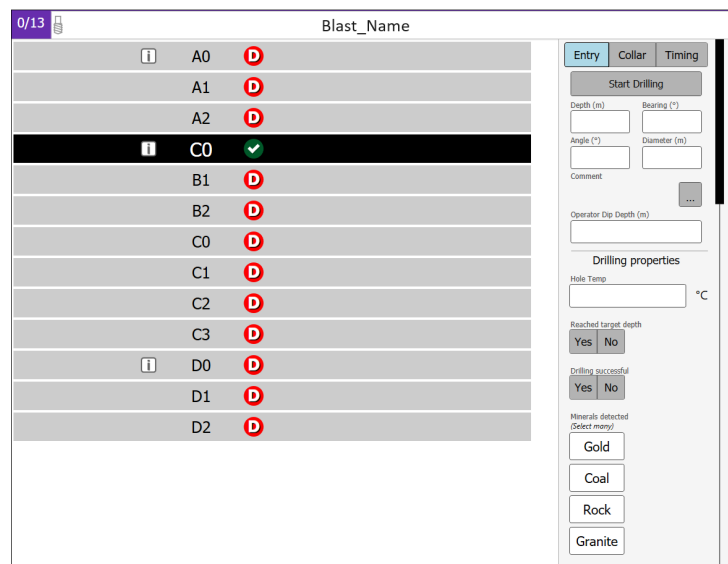

**Figure 7-8** The panel with property fields of a hole that was marked drilled

- a. Enter the **Depth**, **Angle**, **Bearing**, **Diameter**, and the **Operator Dip Depth** in the **Entry** tab of the panel.

**Note:** To enter any comments, click the  button in the **Comment** field. See [Entering comments](#) for more information.

- b. Enter the data in the **Drilling properties** section. If you have not entered any hole properties, you can still do so by scrolling down this panel and entering the required information.
3. Set the location by completing the following steps:
  - a. Open the **Collar** tab.
  - b. Open the **Map** view.
  - c. Tap the **Pick Location** button.

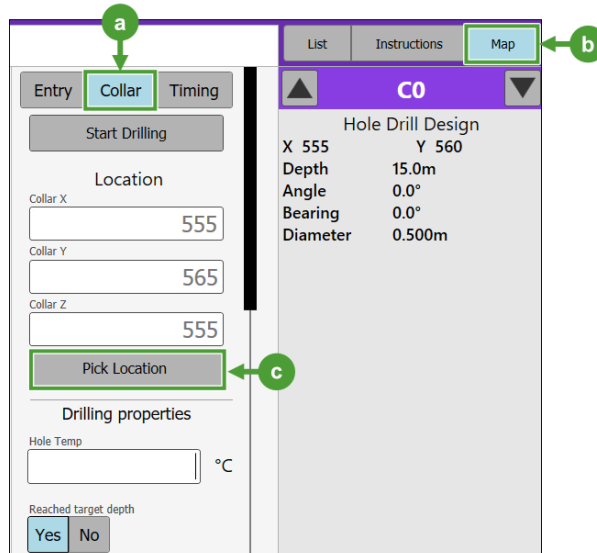

Figure 7-9 Selecting location for a drillhole (1)

- d. Pick a location in the **Map** view.
  - e. Tap **Picked**.

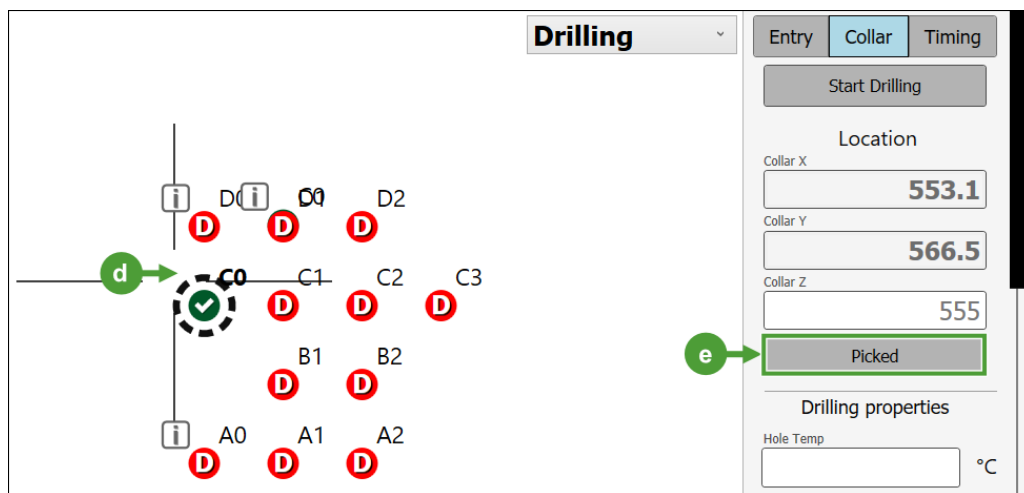

Figure 7-10 Selecting location for a drillhole (2)

**Note:** You can also enter the location manually, by entering the coordinates for the **Collar X**, **Collar Y**, and **Collar Z** fields. Once you have entered the required location information manually, tap **Picked** to confirm your settings.

4. On the **Timing** tab, set the **Start Date** and the **End Date** of the drilling operation.

Figure 7-11 Start Date and End Date setting panel

- Enter the dates manually in the fields or select them in the calendar after tapping the button.
- Enter the time by tapping on the fields corresponding to **Start Time** and **End Time** and selecting the required hour and minute value from the drop-down menu.

**Tip:** Tap the button to set the **Start Date** and **Start Time** to the current time.

5. Once you have applied the required settings, tap **Start Drilling** on the **Entry**, **Collar**, or **Timing** tab.

The **Drilling duration** timer will appear in the **Timing** tab. Tap **Stop Drilling** when the drilling is finished.

Figure 7-12 Drilling duration displayed after tapping the Stop Drilling button

## 7.4 Redrilling a hole

You can redrill a hole by completing the following steps:

1. Tap a hole from the list on the left or directly select a hole in **Map** view.
2. Tap the **Redrill** button on the right.

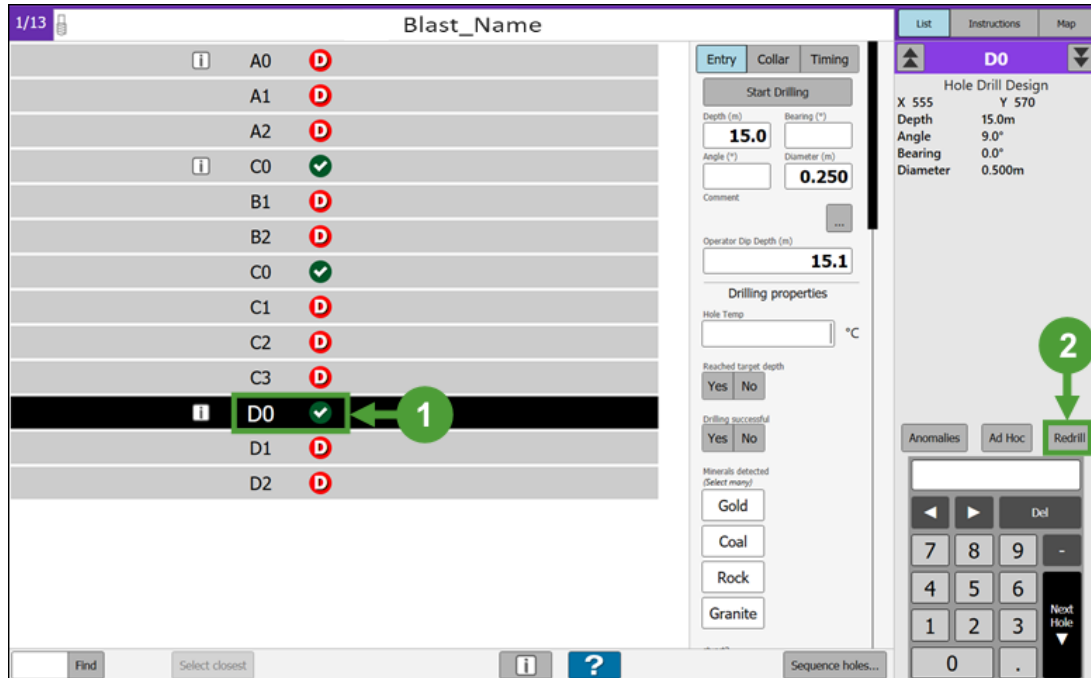

Figure 7-13 Redrilling the selected hole

3. Follow the operation sequence described in [Entering drilling data for a drillhole](#).

## 7.5 Creating an ad hoc hole

To add a hole to your blast, you can create an ad hoc hole.

Follow these steps to add an ad hoc hole to your setup:

1. Tap the **Ad Hoc** button on the right side of your screen.

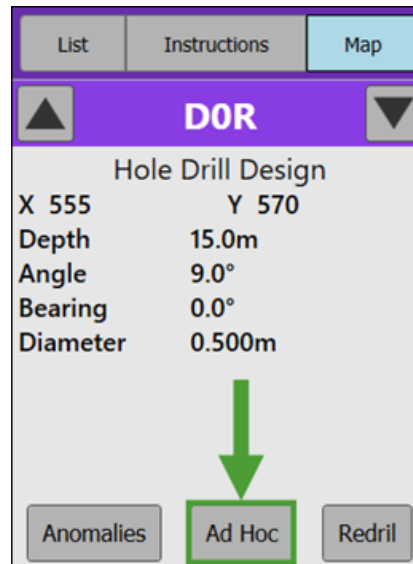

Figure 7-14 The **Ad Hoc** button on the right-hand side of the screen

2. Enter a hole name.
3. Specify the location of the new hole. You can enter the location either manually (in the **Collar X**, **Collar Y**, and **Collar Z** fields), or specify it in the **Map** view.
4. Tap the **Picked** button to confirm your selection.
5. Tap **Create** to add the new hole to your blast.

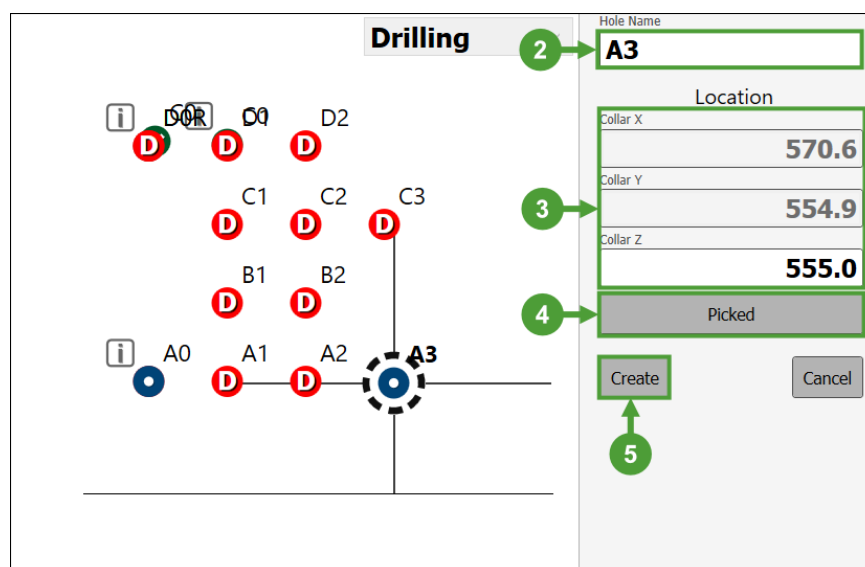

Figure 7-15 The operation sequence for creating an add hoc hole

# 8. Entering Dip Data I

Use the **Dipping** module to enter dipping data.

## 8.1 Getting started

To load the **Dipping** module, go to the **Site Home** page and tap the **Dipping** button.

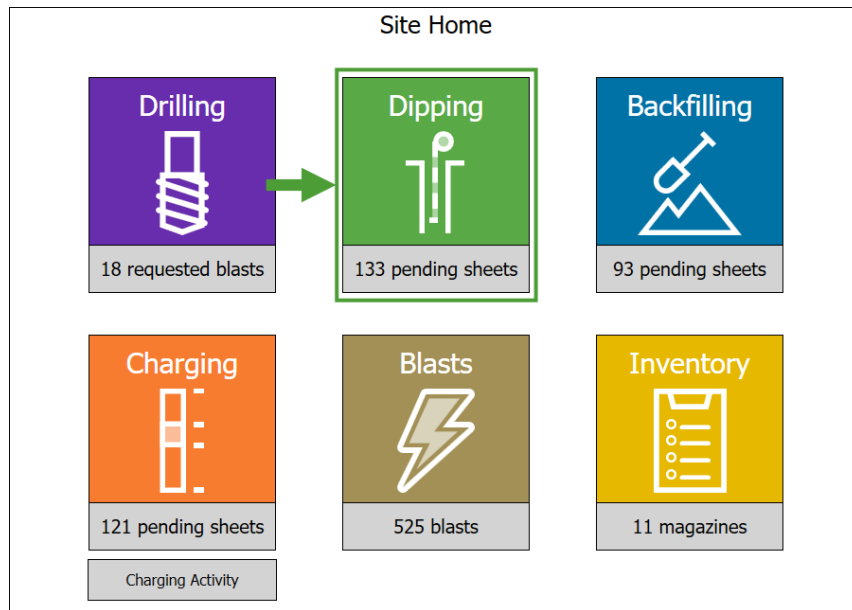
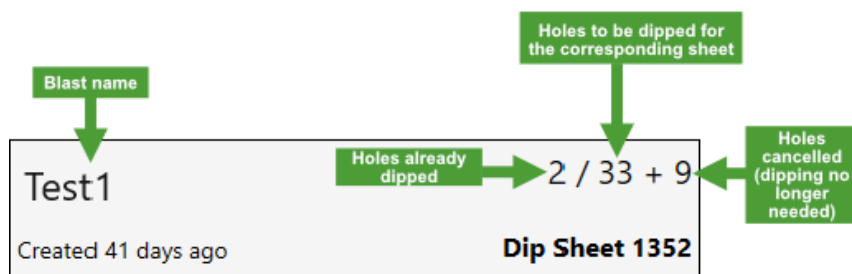

**Figure 8-1** Entering the **Dipping** module from the **Site Home** screen

A list of blasts with dip sheets saved in your database will appear. The blasts will be grouped into the following tabs:

- **Incomplete**
- **Completed in last 24 hours**

The following hole information is provided for each blast on the list:



**Figure 8-2** The dipping state of holes in a blast

Navigate to the blast you would like to enter data for and tap **Open**.

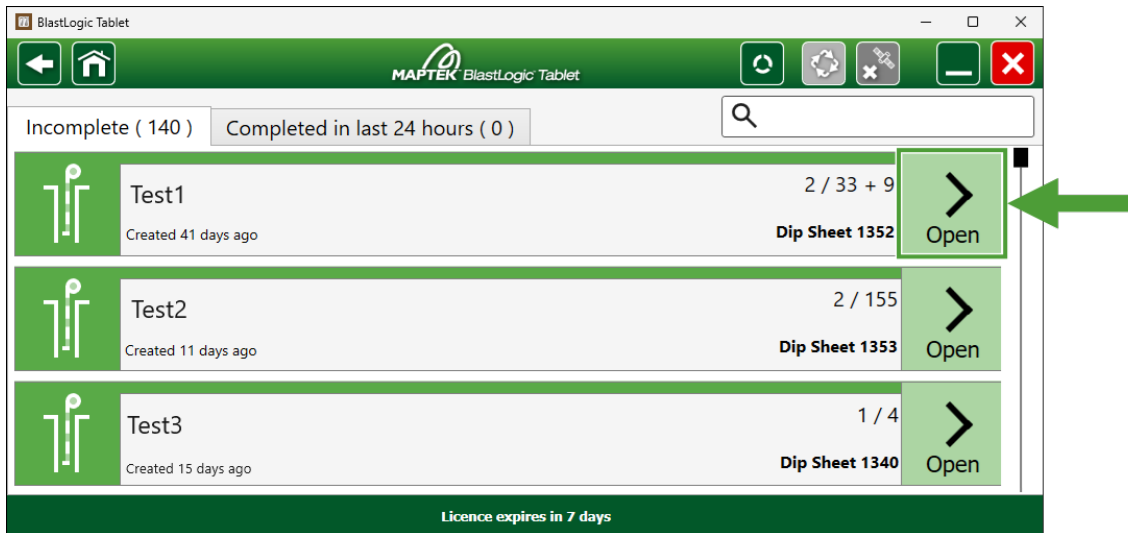

Figure 8-3 Selecting a blast to open in the Dipping module

**Tip**

Use the search field to filter the list of displayed blasts and their associated dip sheets. As you enter the characters constituting the required phrase into the search field, the BlastLogic Tablet will dynamically show the blasts and sheets that include matches, even if your phrase is part of a longer word.

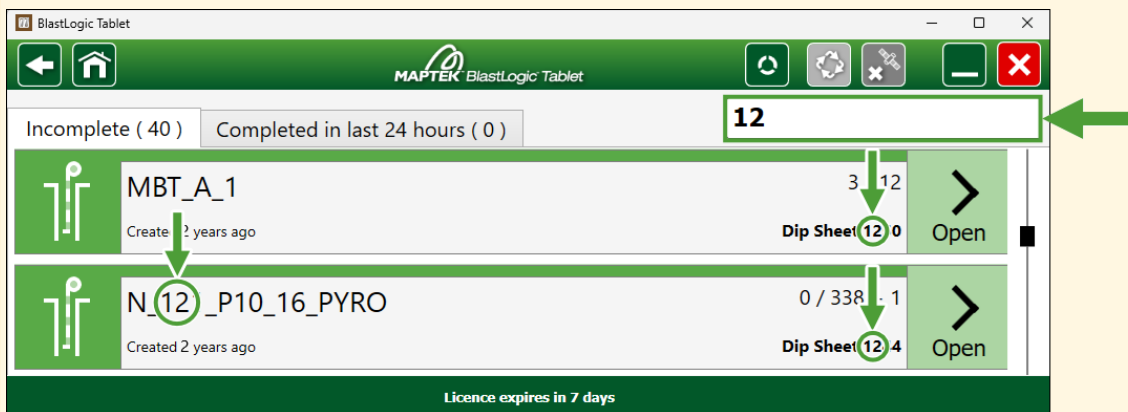

Figure 8-4 Using the search field to navigate to the required blast

Select the crew and supervisor, then tap **Continue**.

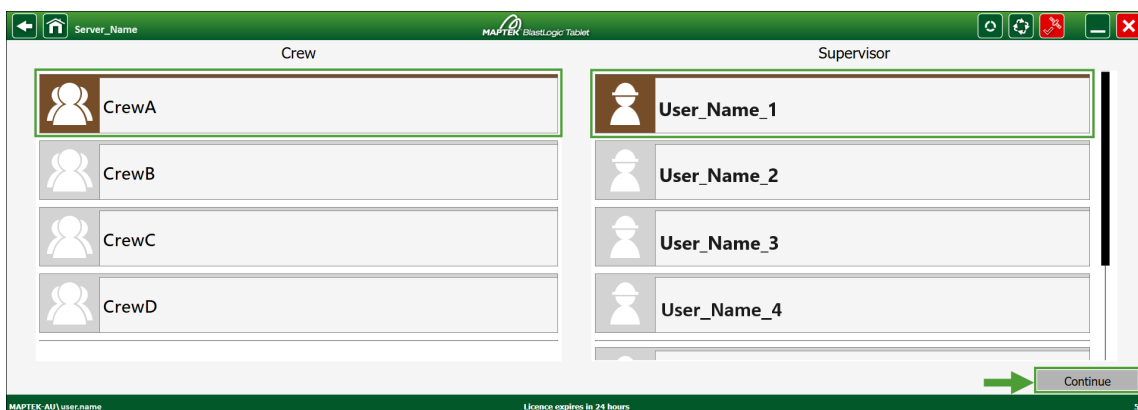



Figure 8-5 Entering the Dipping module after selecting a crew and supervisor

## 8.2 Hole status in Dipping module

The status of each hole in your view is indicated by an icon.

You can check the meaning of each icon on the pop-up window that appears when you tap the  button on your task bar.

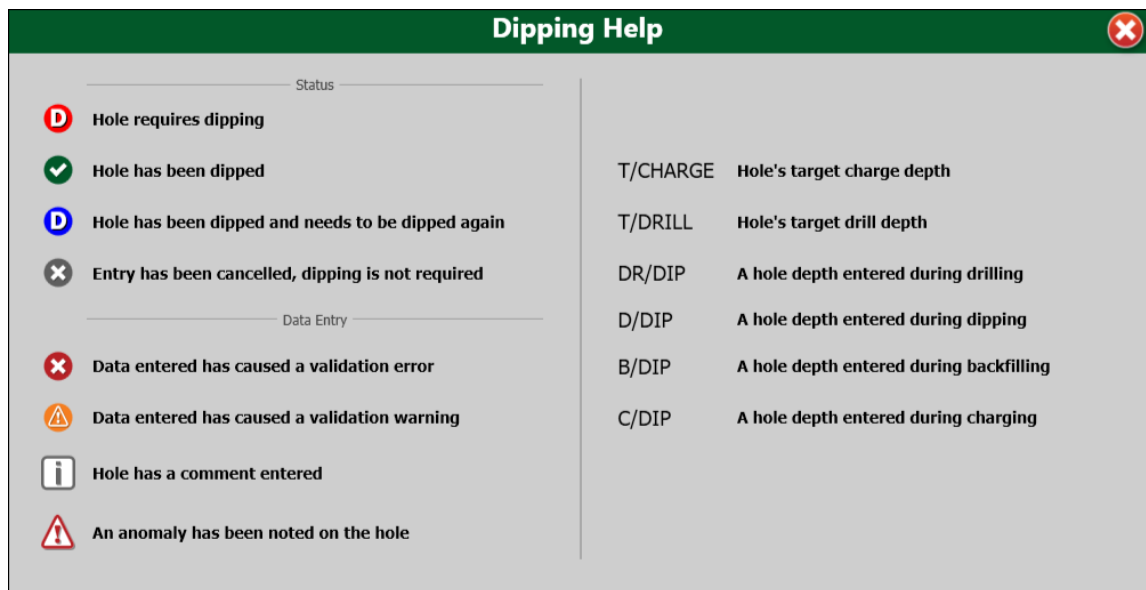



Figure 8-6 Hole status in the Dipping module

## 8.3 Table view

The **Table** view provides you with a list of holes where you can enter the dip information and related comments.

To enter dip data, select the **Dip**, **Water**, and **Wet sides** cells of a hole (the entire row will be highlighted, and the cells will become active for input).

 **Note:** The **Table** view also allows you to enter the hole properties by inputting the corresponding information on the right side of the screen.



To enter the information, use the numeric keypad on your right.

 **Note:** **Wet sides** value needs to be greater than water length.  
Example:  
**Water:** 3 m, **Wet sides:** 5m (including the hole length under water).

Repeat the input for other holes in your blast.

**Tip**

To move to the next hole, do one of the following:

- Select next hole manually by tapping it.
- Tap **Next Hole** on the numeric keypad.
- Move to the first hole (next page) that is not visible in your current view by tapping the  button. Tap  to return to the previous view.

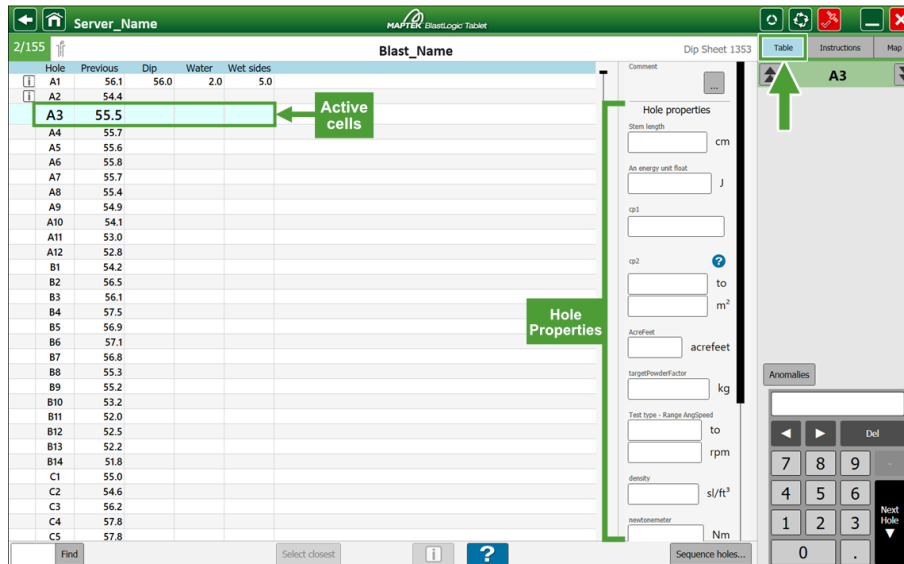

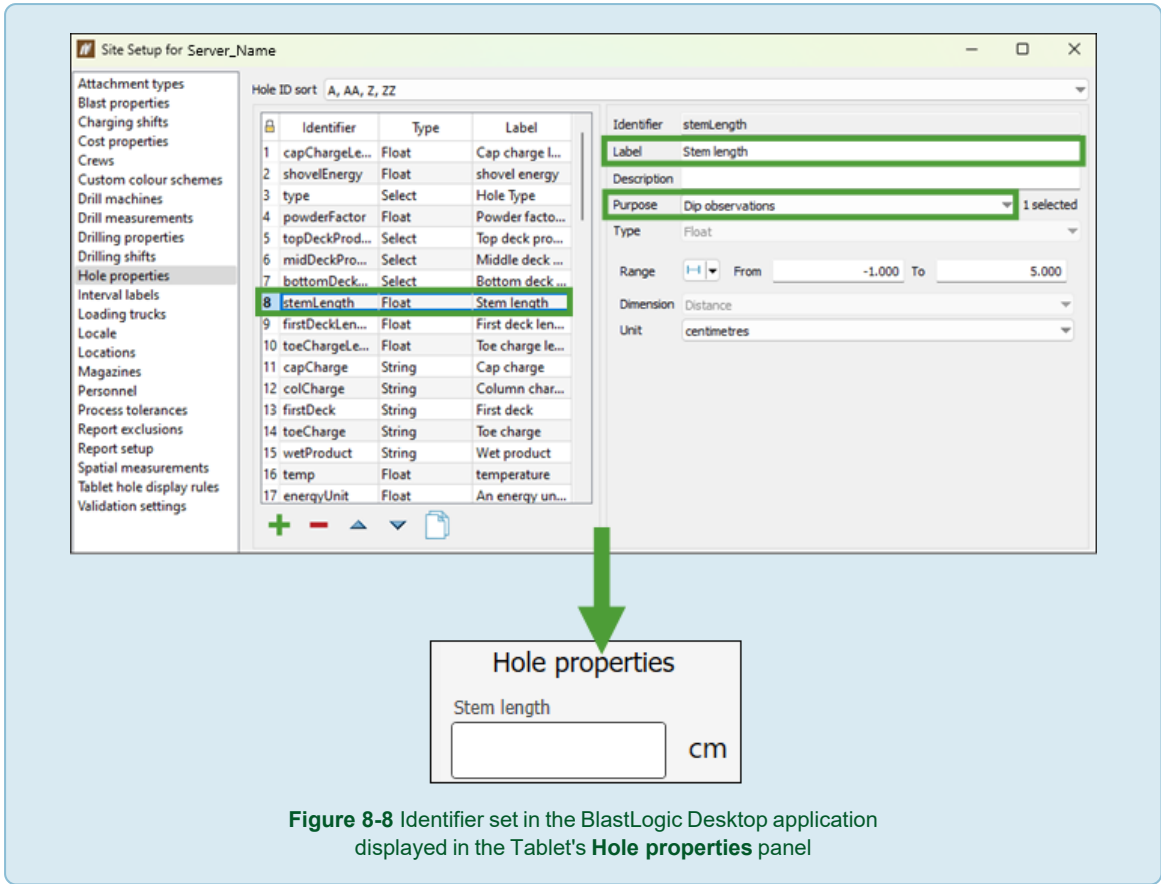

Figure 8-7 Entering dip information and properties for a selected hole in the Table view

**Note**

The **Hole properties** shown in the **Dipping** module correspond to the identifiers you have set in the **Hole properties** panel in the BlastLogic Desktop application (**Home** ribbon > **Setup** group > **Site** >  **Hole properties**).



**Figure 8-8** Identifier set in the BlastLogic Desktop application displayed in the Tablet's **Hole properties** panel

## 8.4 Map view

The **Map** view visualises the location of holes in your blast.

To enter data for each hole, follow these steps:

1. Select a hole on the map.
2. Enter the dipping parameters (**Dip**, **Water**, **Wet sides**) using the numeric keypad.

**Note:** **Wet sides** value needs to be greater than water length.

Example:

**Water:** 3 m, **Wet sides:** 5m (including the hole length under water).

3. Enter the **Hole properties** data.

**Note**

The **Hole properties** shown in the **Dipping** module correspond to the identifiers you have set in the **Hole properties** panel in the BlastLogic Desktop application (**Home** ribbon > **Setup** group > **Site** > **Hole properties**).

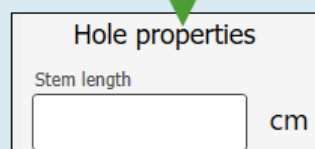
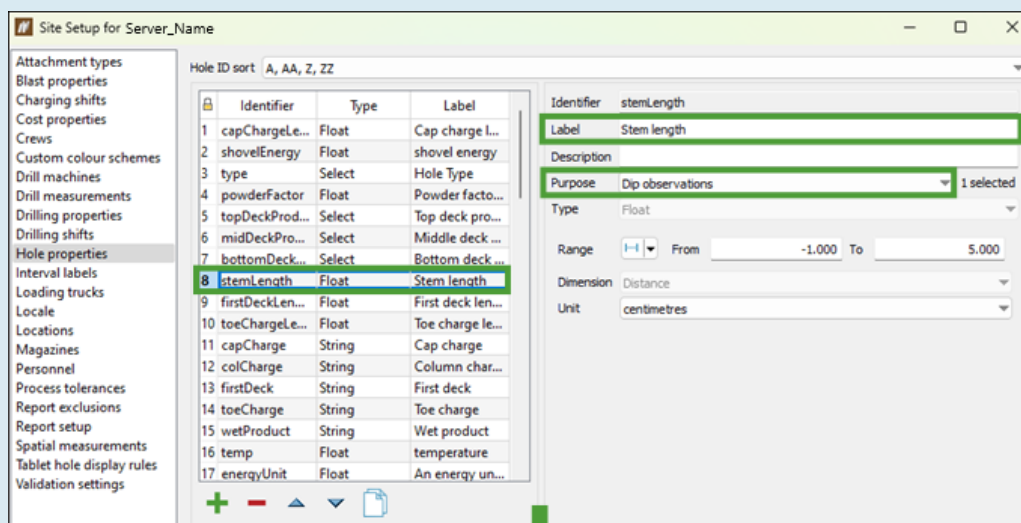



**Figure 8-9** Identifier set in the BlastLogic Desktop application displayed in the Tablet's **Hole properties** panel

4. Repeat these steps for other holes in your blast.

**Tip**

To move to the next hole, do one of the following:

- Select next hole manually by tapping it.
- Tap **Next Hole** on the numeric keypad.
- Press the  button to move to the next hole; press the  button to move to the previous hole.

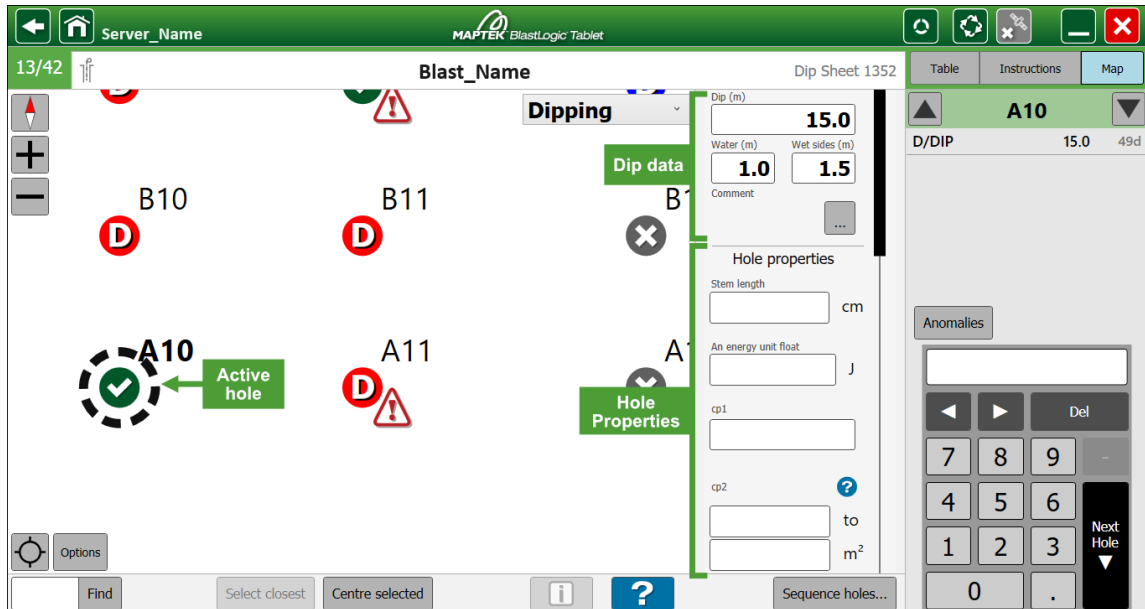

Figure 8-10 Entering dip information and properties for a selected hole in the Map view

# 9. Entering Backfill Data |

Use the **Backfilling** module to enter backfill data.

## 9.1 Getting started

To load the **Backfilling** module, go to the **Site Home** page and tap the **Backfilling** button.

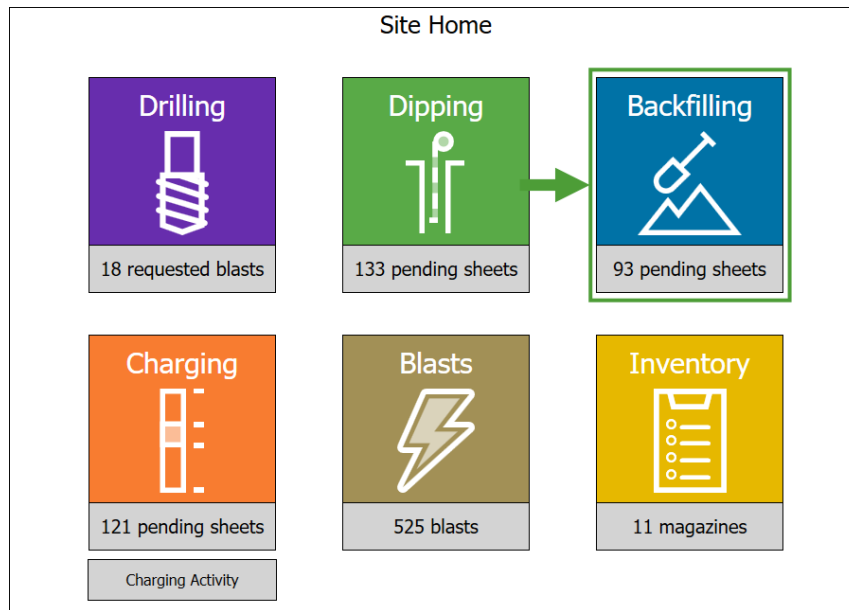
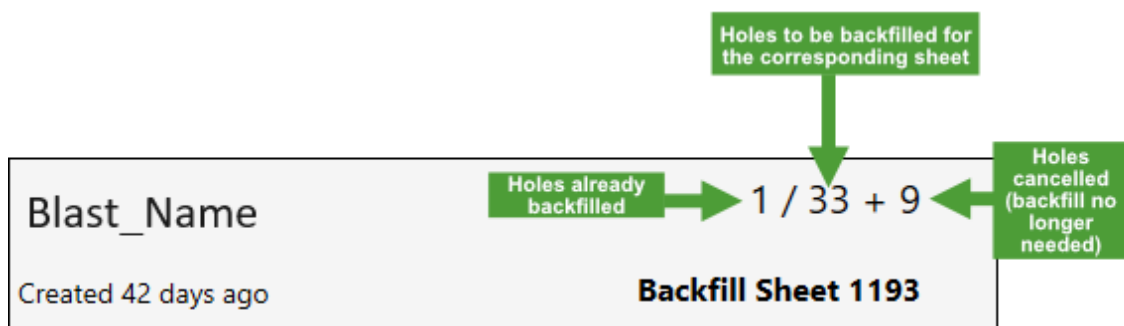

**Figure 9-1** Entering the **Backfilling** module from the **Site Home** screen

A list of blasts with backfill sheets saved in your database will appear. The blasts will be grouped into the following tabs:

- **Incomplete**
- **Completed in last 24 hours**

The following hole information is provided for each blast on the list:



**Figure 9-2** The backfilling state of holes in a blast

Navigate to the blast you would like to enter data for and tap **Open**.

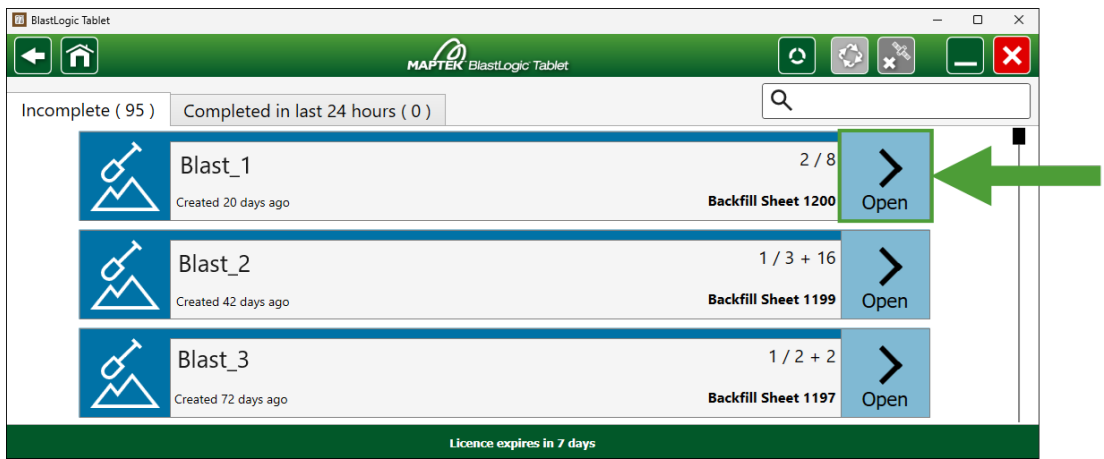

Figure 9-3 Selecting a blast to open in the Backfilling module

**Tip**

Use the search field to filter the list of displayed blasts and their associated backfill sheets. As you enter the characters constituting the required phrase into the search field, the BlastLogic Tablet will dynamically show the blasts and sheets that include matches, even if your phrase is part of a longer word.

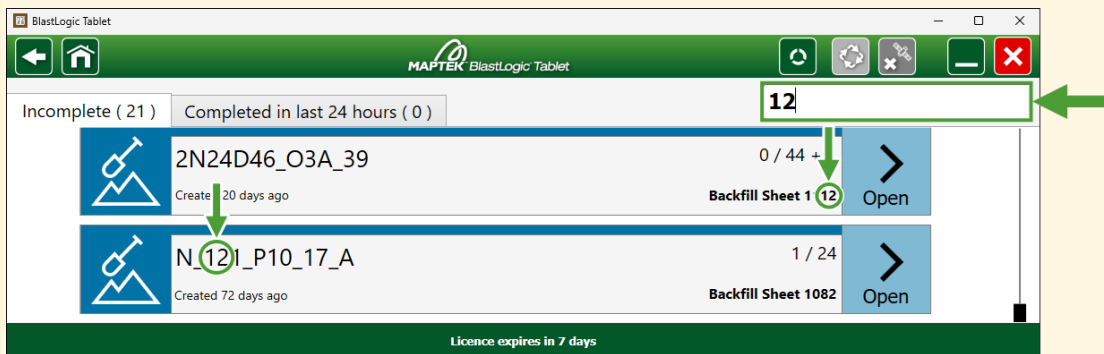

Figure 9-4 Using the search field to navigate to the required blast

Select the crew and supervisor, then tap **Continue**.



Figure 9-5 Entering the Backfilling module after selecting a crew and supervisor

## 9.2 Hole status in backfilling module

The status of each hole in your view is indicated by an icon.

You can check the meaning of each icon on the pop-up window that appears when you tap the  button on your task bar.

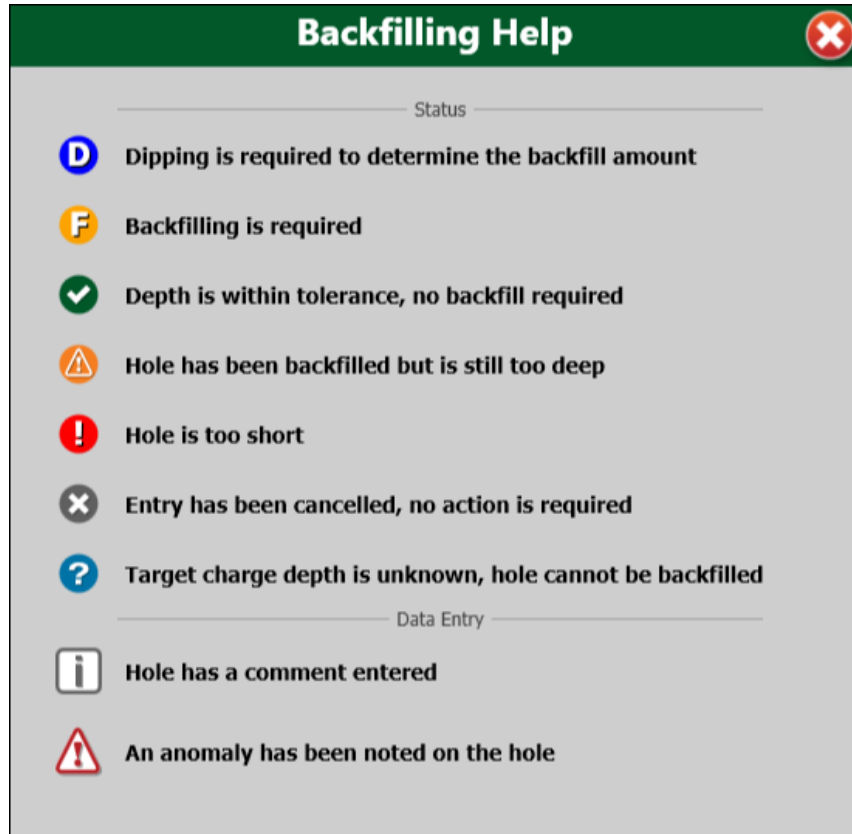

Figure 9-6 Hole status in the **Backfilling** module

## 9.3 List view

The **List** view features information on all holes in your blast.

To view or enter detailed data for a hole, tap it on the list and, using the numeric keypad, input the required measurements on the right side of your screen.

**Note:** **Wet sides** value needs to be greater than water length.

Example:

**Water:** 3 m, **Wet sides:** 5m (including the hole length under water).

The screenshot shows a list of holes on the left and a detailed form on the right. The list includes holes A4 through B6, with A6 selected. The form on the right is titled 'Dipping required' and contains the following sections:

- Backfill required:** Includes 'Backfilled' and 'Not backfilled' buttons.
- After backfilling:** Includes a 'Dip (m)' input field and a 'Comment' field with a menu icon.
- Hole properties:** Includes 'cp1' and 'cp2' input fields, with 'cp2' having a unit 'm²' and a question mark icon.

Green callout boxes on the right side of the form label the 'Backfill data' section (covering the backfill required and after backfilling parts) and the 'Hole properties' section.

**Figure 9-7** Entering backfill information and properties for a selected hole in the **List** view

To confirm that the right amount of backfill has been added to the hole, tap **Backfilled**. Repeat the input for other holes in your blast.

**Note**

The **Hole properties** shown in the **Backfilling** module correspond to the identifiers you have set in the **Hole properties** panel in the BlastLogic Desktop application (**Home** ribbon > **Setup** group > **Site** > **Hole properties**).

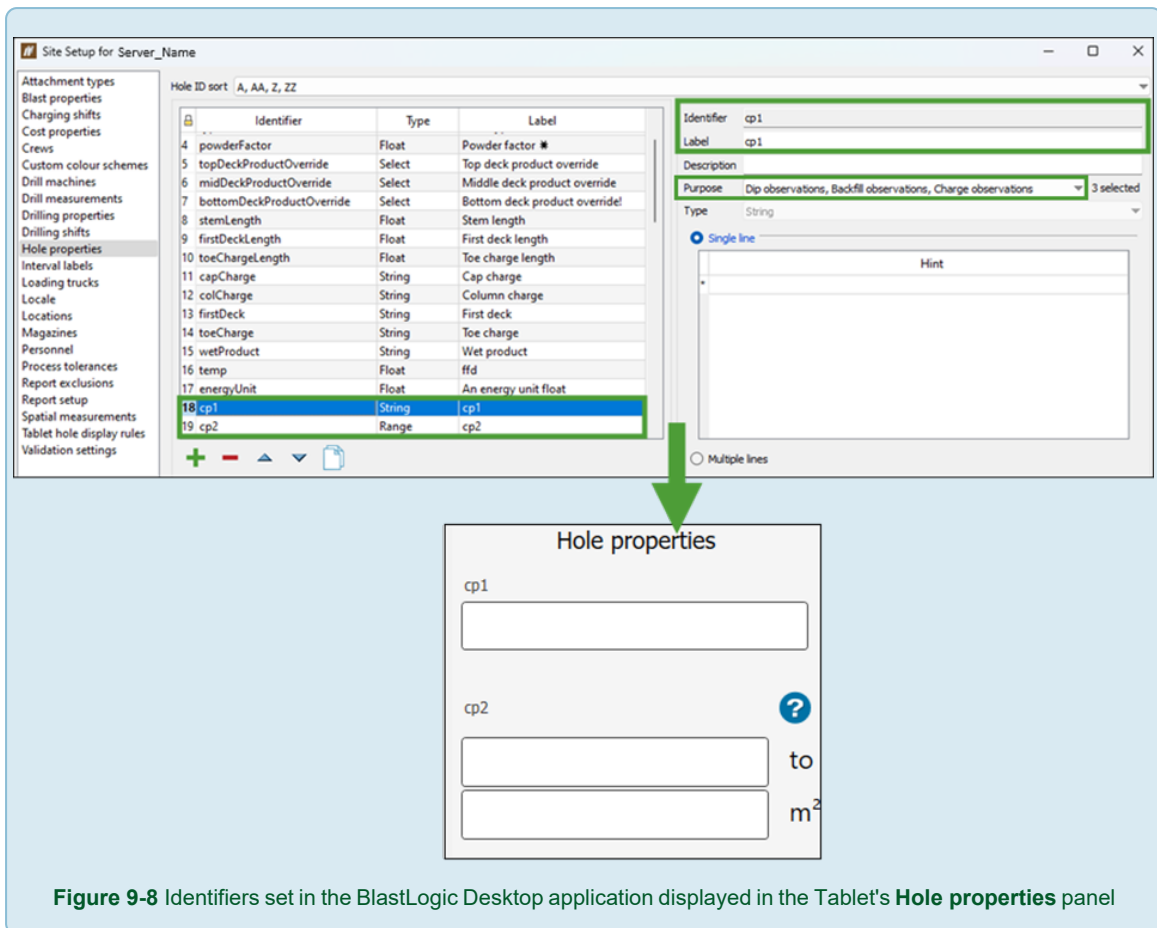

**Figure 9-8** Identifiers set in the BlastLogic Desktop application displayed in the Tablet's **Hole properties** panel

**Tip**

To move to the next hole, do one of the following:

- Select next hole manually by tapping it.
- Tap **Next Hole** on the numeric keypad.
- Move to the first hole (next page) that is not visible in your current view by tapping the button. Tap to return to the previous view.

## 9.4 Map view

The **Map** view visualises the location of holes in your blast.

To enter data for each hole, follow these steps:

1. Select a hole on the map.
2. Enter the backfilling parameters (**Dip, Water, Wet sides**) using the numeric keypad.

**Note:** **Wet sides** value needs to be greater than water length.

Example:

**Water:** 3 m, **Wet sides:** 5m (including the hole length under water).

- Enter the **Hole properties** data.

**Note**

The **Hole properties** shown in the **Backfilling** module correspond to the identifiers you have set in the **Hole properties** panel in the BlastLogic Desktop application (**Home** ribbon > **Setup** group > **Site** > **Hole properties**).

**Figure 9-9** Identifiers set in the BlastLogic Desktop application displayed in the Tablet's **Hole properties** panel

- To confirm that the right amount of backfill has been added to the hole, tap **Backfilled**.
- Repeat these steps for other holes in your blast.

**Tip**

To move to the next hole, do one of the following:

- Select next hole manually by tapping it.
- Tap **Next Hole** on the numeric keypad.
- Press the button to move to the next hole; press the button to move to the previous hole.

# 10. Entering Charge Data I

## 10.1 Getting started

To load the **Charging** module, go to the **Site Home** page and tap the **Charging** button.

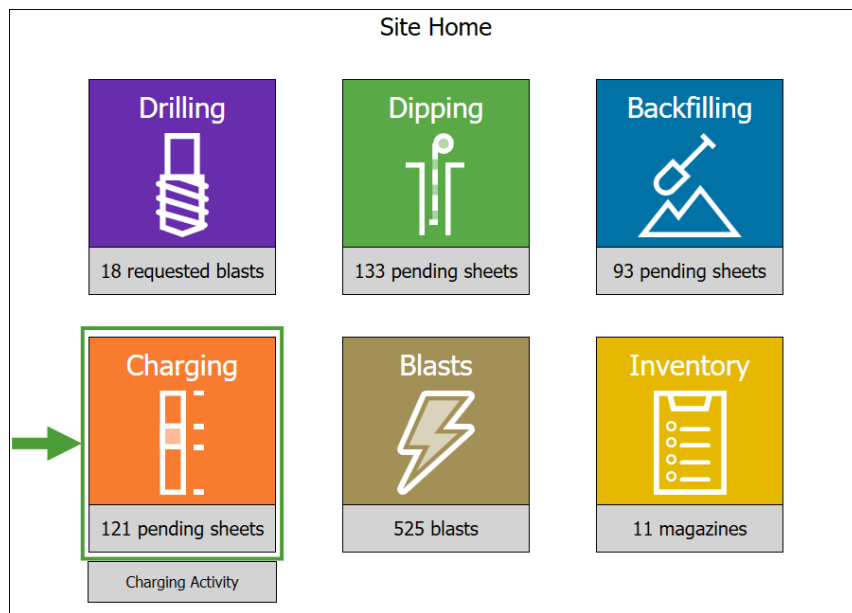
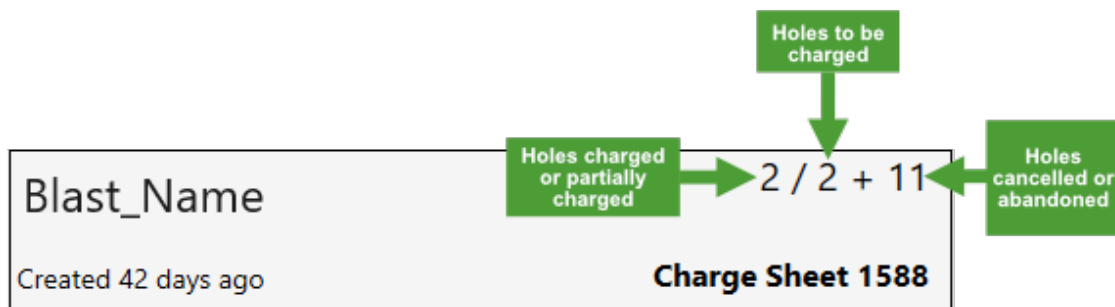

**Figure 10-1** Entering the **Charging** module from the **Site Home** screen

A list of blasts with charge sheets saved in your database will appear. The blasts will be grouped into the following tabs:

- **Incomplete**
- **Completed in last 24 hours**

The following hole information is provided for each blast on the list:



**Figure 10-2** The charging state of holes in a blast

Navigate to the blast you would like to enter data for and tap **Open**.

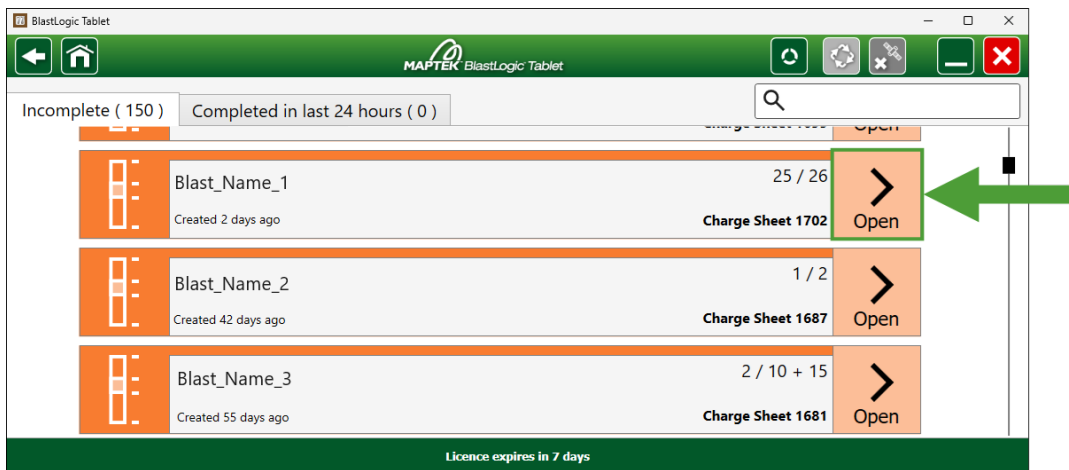

Figure 10-3 Selecting a blast to open in the **Charging** module

**Tip**

Use the search field to filter the list of displayed blasts and their associated charge sheets. As you enter the characters constituting the required phrase into the search field, the BlastLogic Tablet will dynamically show the blasts and sheets that include matches, even if your phrase is part of a longer word.

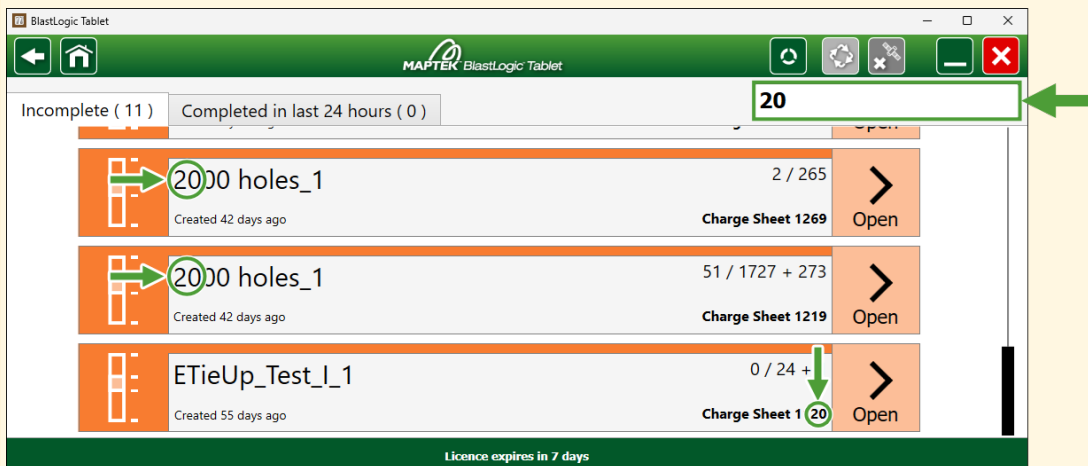

Figure 10-4 Using the search field to navigate to the required blast

Select the crew, shotfirer, loading truck, and operator, then tap **Continue**.

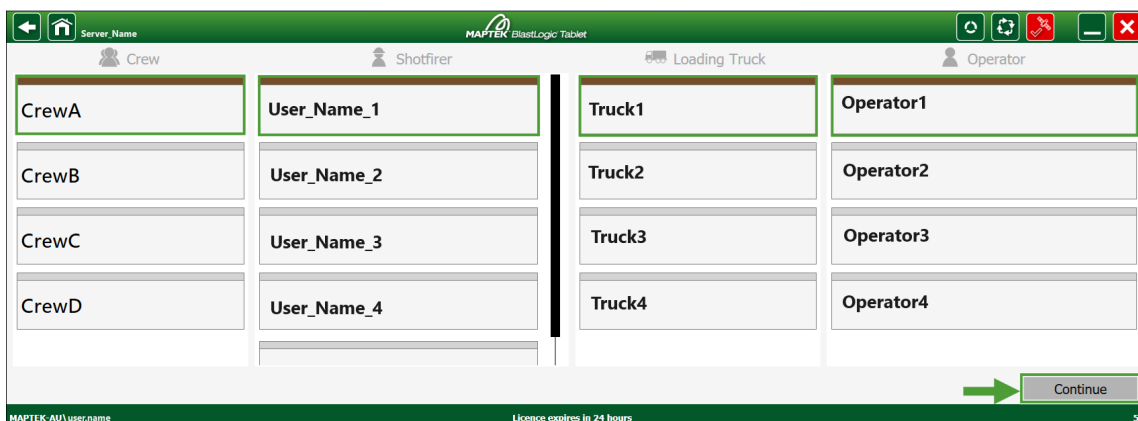

Figure 10-5 Entering the **Charging** module after selecting a crew, shotfirer, loading truck, and supervisor

## 10.2 Charge data entry views

There are four views where you can view and enter charging-related data:

- **Preview:** Shows the currently selected hole and the next hole.
- **Instructions:** Reflects the information that you have entered when creating a corresponding sheet in the BlastLogic Desktop application. See [6.8 Instructions tab](#) on page 26 for more information.
- **Open Cup:** Allows you to add density measurements to the holes in the blast.
- **Map view:** Visualises the location of holes in your blast and a cross-section of the currently selected hole.

### Note:

The **Hole properties** shown in the **Charging** module's **Preview** and **Map** view correspond to the identifiers you have set in the **Hole properties** panel in the BlastLogic Desktop application (**Home ribbon > Setup group > Site > Hole properties**).

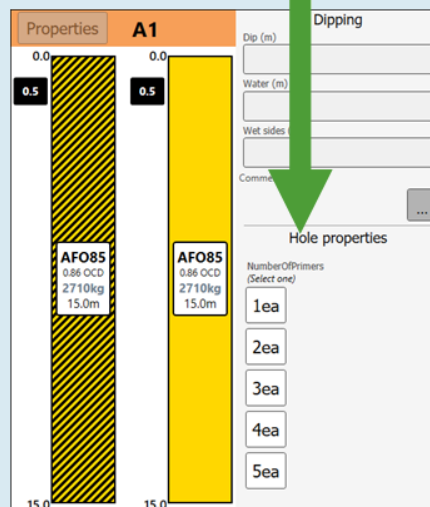
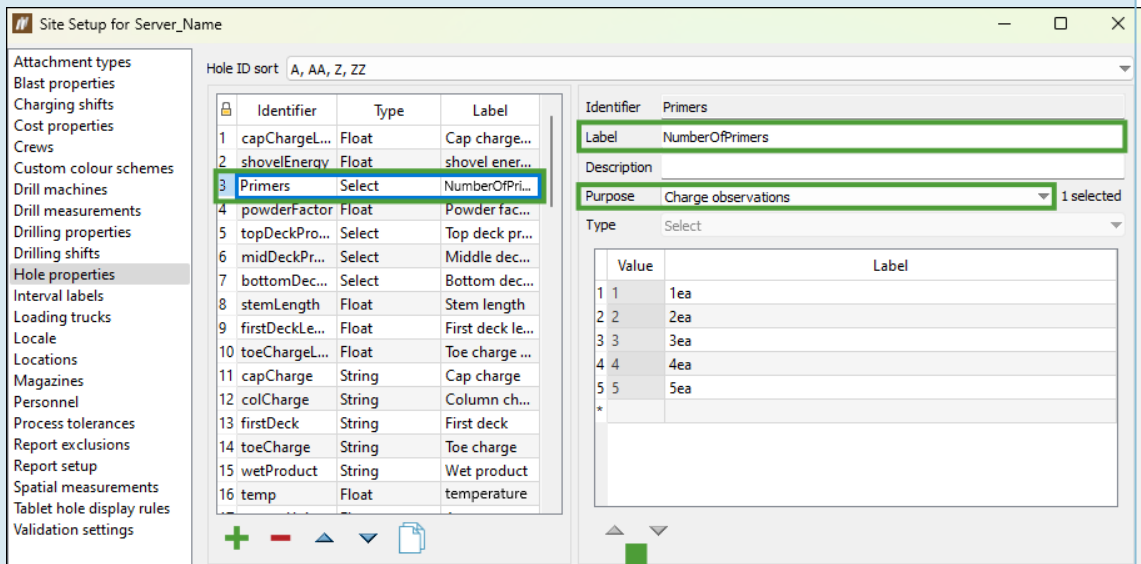

## 10.2.1 Preview

The **Preview** view shows the charging data on the currently selected hole and the next hole.

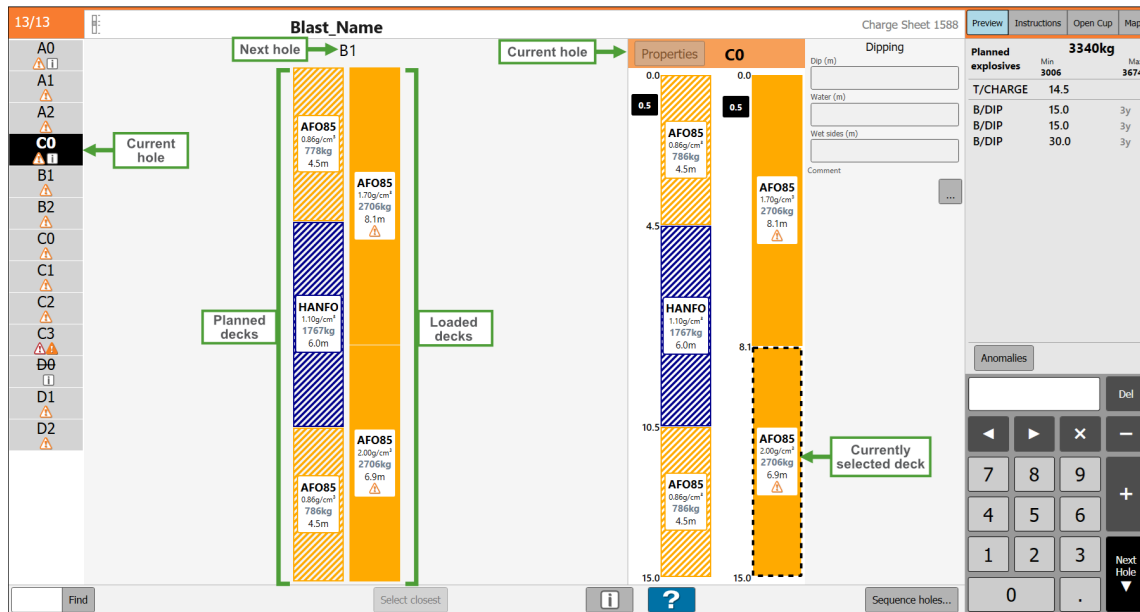

Figure 10-6 Planned and loaded charging decks in the current and next hole

The water within a hole is represented by the solid blue line, whereas the wet sides are marked with a dotted blue line, as shown below:

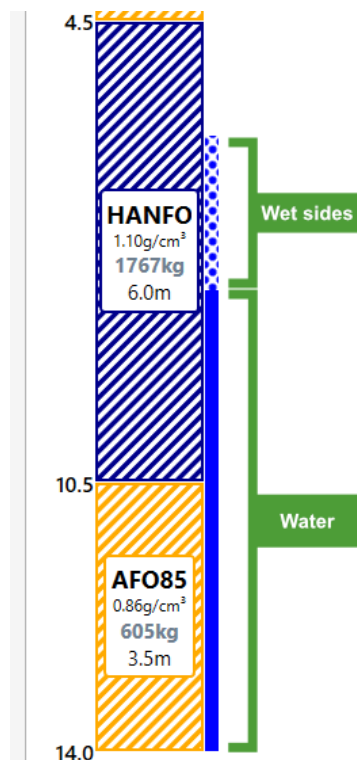

Figure 10-7 Water and wet sides reflected in the hole view

The red line represents the depth of the hole whilst charging. The depth of the hole will influence the charging plan.

If the Tablet cannot produce a charging plan with the new depth, an error will occur, and the red wavy line will be visible.

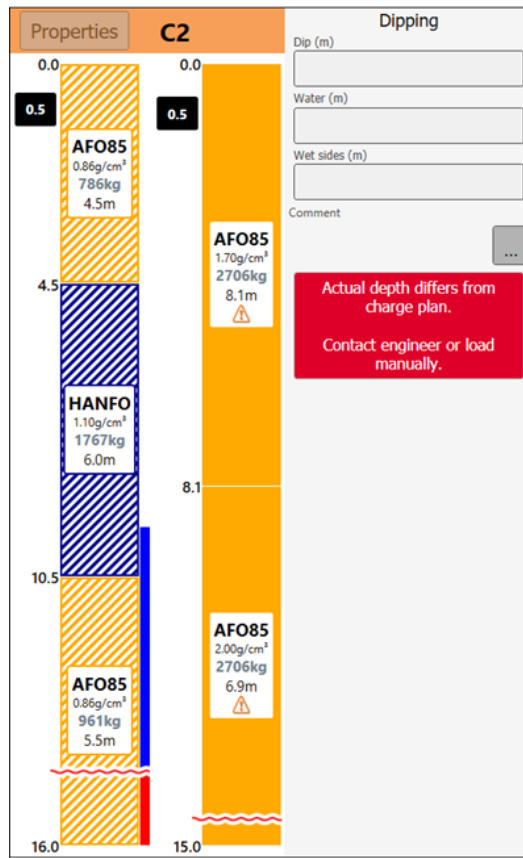

Figure 10-8 Error information (example)

## 10.2.2 Open Cup view

The **Open Cup** view allows you to add density measurements to the holes in the blast.

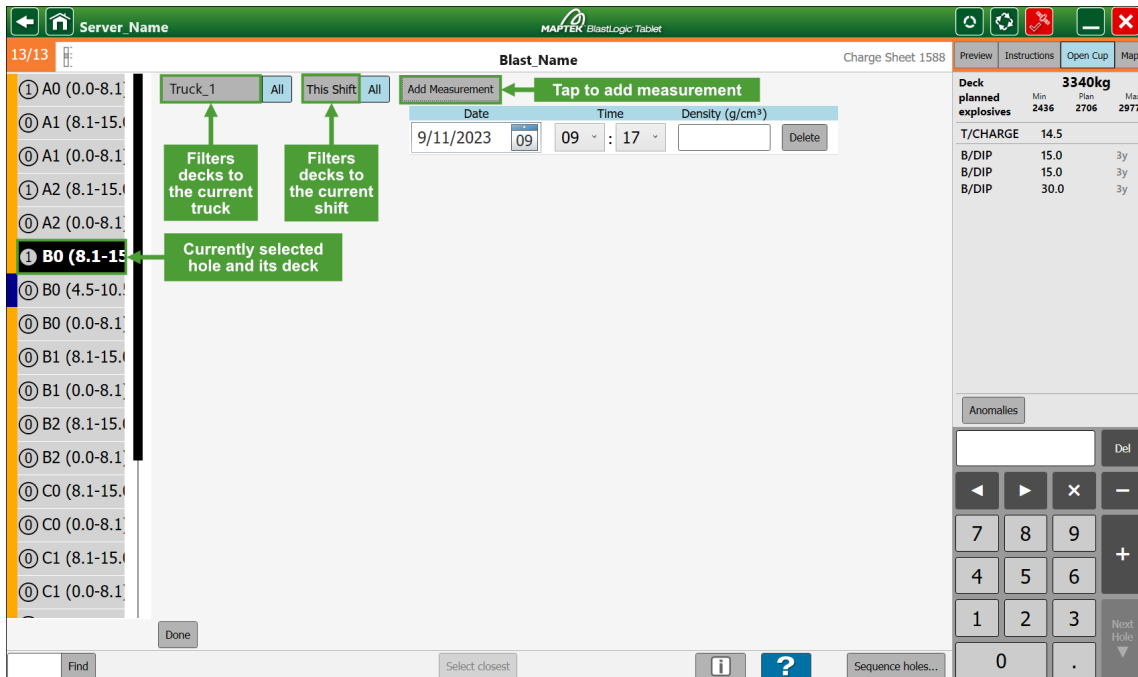



Figure 10-9 Open cup view for a selected hole

To add a density measurement, select the required hole (the decks corresponding to each hole are also shown on the list), tap **Add Measurement** and enter the date, time, and the measured value. Tap **Done** to confirm your entry.

**Tip:** Tap the  button to set the **Start Date** and **Start Time** to the current time.

## 10.2.3 Map view

The **Map** view visualises the location of holes in your blast and a cross-section of the currently selected hole.

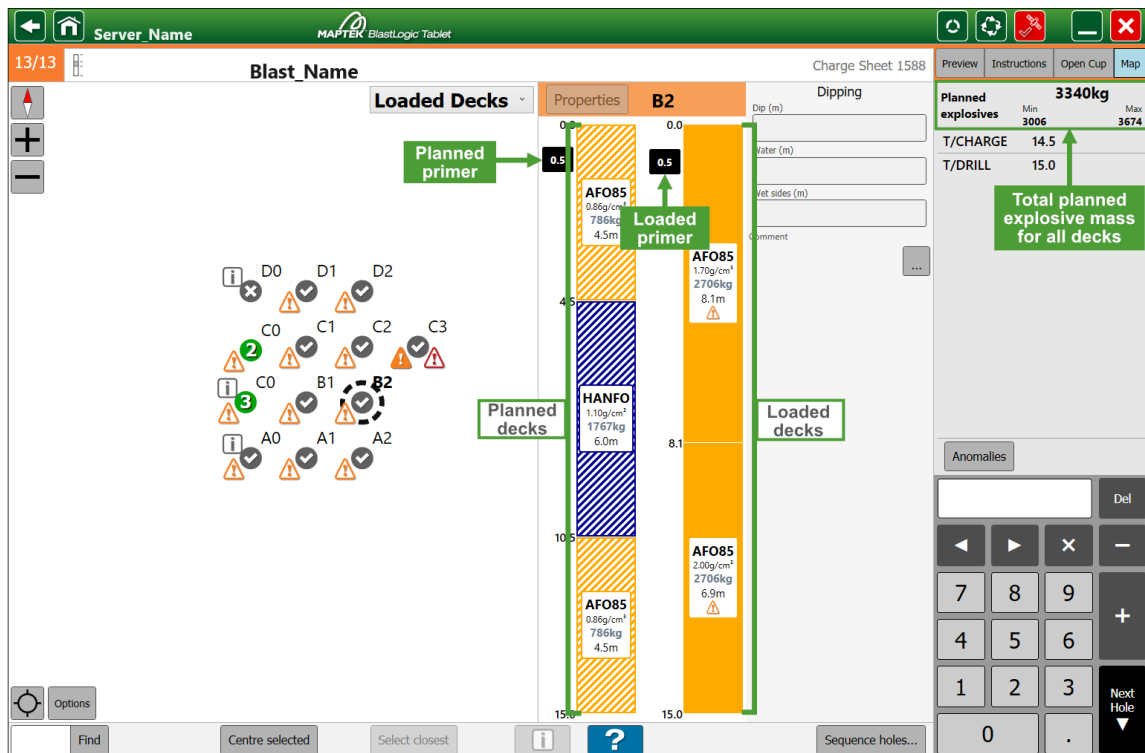

Figure 10-10 Map view for a selected hole

You can change the way your holes are displayed in the **Map** view by selecting an option from the drop-down menu:

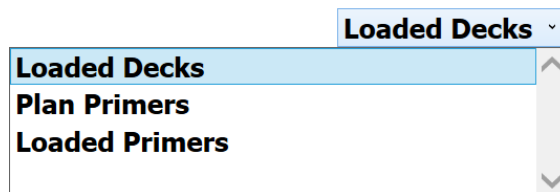

Figure 10-11 Display modes available in the Map view

The status of each hole in your view is indicated by an icon.

You can check the meaning of each icon on the pop-up window that appears when you tap the **?** button on your task bar.

**Loaded Decks**  
display mode

**Charging Help**
✕

<ul style="list-style-type: none"> <li><span style="color: red; font-weight: bold; font-size: 1.2em;">E</span> Hole has not been charged</li> <li><span style="color: orange; font-weight: bold; font-size: 1.2em;">F</span> Backfilling is required</li> <li><span style="color: red; font-weight: bold; font-size: 1.2em;">1</span> One explosive deck has been loaded to 10% of design charge mass *</li> <li><span style="color: orange; font-weight: bold; font-size: 1.2em;">1</span> One explosive deck has been loaded to 50% of design charge mass *</li> <li><span style="color: green; font-weight: bold; font-size: 1.2em;">2</span> Two explosive decks have been loaded to 90% of design charge mass *</li> <li><span style="color: blue; font-weight: bold; font-size: 1.2em;">✓</span> All decks are loaded within tolerance of the plan</li> <li><span style="color: grey; font-weight: bold; font-size: 1.2em;">✓</span> Hole has been flagged as charged by the Engineer. Loaded decks and primers should not be changed.</li> <li><span style="color: red; font-weight: bold; font-size: 1.2em;">✕</span> Entry has been cancelled, charging is not required</li> </ul> <p style="font-size: 0.8em; margin-top: 10px;">* Adjacent explosive decks of the same product are counted as one deck. The colour changes from Red (1%) through to Orange / Brown (50%) through to Green (100% or over).</p>	<table style="width: 100%; border-collapse: collapse;"> <tr><td style="width: 150px;">T/CHARGE</td><td>Hole's target charge depth</td></tr> <tr><td>T/DRILL</td><td>Hole's target drill depth</td></tr> <tr><td>DR/DIP</td><td>A hole depth entered during drilling</td></tr> <tr><td>D/DIP</td><td>A hole depth entered during dipping</td></tr> <tr><td>B/DIP</td><td>A hole depth entered during backfilling</td></tr> <tr><td>C/DIP</td><td>A hole depth entered during charging</td></tr> <tr><td><span style="color: red; font-size: 1.2em;">⚠</span></td><td>An anomaly has been noted on the hole</td></tr> <tr><td><span style="color: orange; font-size: 1.2em;">⚠</span></td><td>Hole is loaded outside mass or length tolerance, or the quantity differs</td></tr> <tr><td><span style="color: orange; font-size: 1.2em;">⚠</span></td><td>Hole is not stemmed / is stemmed out of tolerance, or the top explosive deck is out of tolerance</td></tr> <tr><td><span style="border: 1px solid black; padding: 2px 5px; font-size: 0.8em;">i</span></td><td>Hole or deck has a comment entered</td></tr> <tr><td>Av</td><td>Average in-hole density of the bulk explosive</td></tr> <tr><td>OCD</td><td>Open Cup Density of the bulk explosive</td></tr> </table>	T/CHARGE	Hole's target charge depth	T/DRILL	Hole's target drill depth	DR/DIP	A hole depth entered during drilling	D/DIP	A hole depth entered during dipping	B/DIP	A hole depth entered during backfilling	C/DIP	A hole depth entered during charging	<span style="color: red; font-size: 1.2em;">⚠</span>	An anomaly has been noted on the hole	<span style="color: orange; font-size: 1.2em;">⚠</span>	Hole is loaded outside mass or length tolerance, or the quantity differs	<span style="color: orange; font-size: 1.2em;">⚠</span>	Hole is not stemmed / is stemmed out of tolerance, or the top explosive deck is out of tolerance	<span style="border: 1px solid black; padding: 2px 5px; font-size: 0.8em;">i</span>	Hole or deck has a comment entered	Av	Average in-hole density of the bulk explosive	OCD	Open Cup Density of the bulk explosive
T/CHARGE	Hole's target charge depth																								
T/DRILL	Hole's target drill depth																								
DR/DIP	A hole depth entered during drilling																								
D/DIP	A hole depth entered during dipping																								
B/DIP	A hole depth entered during backfilling																								
C/DIP	A hole depth entered during charging																								
<span style="color: red; font-size: 1.2em;">⚠</span>	An anomaly has been noted on the hole																								
<span style="color: orange; font-size: 1.2em;">⚠</span>	Hole is loaded outside mass or length tolerance, or the quantity differs																								
<span style="color: orange; font-size: 1.2em;">⚠</span>	Hole is not stemmed / is stemmed out of tolerance, or the top explosive deck is out of tolerance																								
<span style="border: 1px solid black; padding: 2px 5px; font-size: 0.8em;">i</span>	Hole or deck has a comment entered																								
Av	Average in-hole density of the bulk explosive																								
OCD	Open Cup Density of the bulk explosive																								





**Plan Primers**  
display mode

**Charging Help**
✕

<ul style="list-style-type: none"> <li><span style="color: red; font-weight: bold; font-size: 1.2em;">✕</span> Entry has been cancelled, charging is not required</li> <li><span style="color: red; font-weight: bold; font-size: 1.2em; border-radius: 50%; padding: 2px 5px; display: inline-block; margin-right: 5px;">173</span> Number indicates quantity of planned primers</li> </ul>	<table style="width: 100%; border-collapse: collapse;"> <tr><td style="width: 150px;">T/CHARGE</td><td>Hole's target charge depth</td></tr> <tr><td>T/DRILL</td><td>Hole's target drill depth</td></tr> <tr><td>DR/DIP</td><td>A hole depth entered during drilling</td></tr> <tr><td>D/DIP</td><td>A hole depth entered during dipping</td></tr> <tr><td>B/DIP</td><td>A hole depth entered during backfilling</td></tr> <tr><td>C/DIP</td><td>A hole depth entered during charging</td></tr> <tr><td><span style="color: red; font-size: 1.2em;">⚠</span></td><td>An anomaly has been noted on the hole</td></tr> <tr><td><span style="color: orange; font-size: 1.2em;">⚠</span></td><td>Hole is loaded outside mass or length tolerance, or the quantity differs</td></tr> <tr><td><span style="color: orange; font-size: 1.2em;">⚠</span></td><td>Hole is not stemmed / is stemmed out of tolerance, or the top explosive deck is out of tolerance</td></tr> <tr><td><span style="border: 1px solid black; padding: 2px 5px; font-size: 0.8em;">i</span></td><td>Hole or deck has a comment entered</td></tr> <tr><td>Av</td><td>Average in-hole density of the bulk explosive</td></tr> <tr><td>OCD</td><td>Open Cup Density of the bulk explosive</td></tr> </table>	T/CHARGE	Hole's target charge depth	T/DRILL	Hole's target drill depth	DR/DIP	A hole depth entered during drilling	D/DIP	A hole depth entered during dipping	B/DIP	A hole depth entered during backfilling	C/DIP	A hole depth entered during charging	<span style="color: red; font-size: 1.2em;">⚠</span>	An anomaly has been noted on the hole	<span style="color: orange; font-size: 1.2em;">⚠</span>	Hole is loaded outside mass or length tolerance, or the quantity differs	<span style="color: orange; font-size: 1.2em;">⚠</span>	Hole is not stemmed / is stemmed out of tolerance, or the top explosive deck is out of tolerance	<span style="border: 1px solid black; padding: 2px 5px; font-size: 0.8em;">i</span>	Hole or deck has a comment entered	Av	Average in-hole density of the bulk explosive	OCD	Open Cup Density of the bulk explosive
T/CHARGE	Hole's target charge depth																								
T/DRILL	Hole's target drill depth																								
DR/DIP	A hole depth entered during drilling																								
D/DIP	A hole depth entered during dipping																								
B/DIP	A hole depth entered during backfilling																								
C/DIP	A hole depth entered during charging																								
<span style="color: red; font-size: 1.2em;">⚠</span>	An anomaly has been noted on the hole																								
<span style="color: orange; font-size: 1.2em;">⚠</span>	Hole is loaded outside mass or length tolerance, or the quantity differs																								
<span style="color: orange; font-size: 1.2em;">⚠</span>	Hole is not stemmed / is stemmed out of tolerance, or the top explosive deck is out of tolerance																								
<span style="border: 1px solid black; padding: 2px 5px; font-size: 0.8em;">i</span>	Hole or deck has a comment entered																								
Av	Average in-hole density of the bulk explosive																								
OCD	Open Cup Density of the bulk explosive																								

Loaded Primers  
display mode

### Charging Help ✖

<p>✖ Entry has been cancelled, charging is not required</p> <p>173 Number indicates quantity of loaded primers</p>	<p>T/CHARGE Hole's target charge depth</p> <p>T/DRILL Hole's target drill depth</p> <p>DR/DIP A hole depth entered during drilling</p> <p>D/DIP A hole depth entered during dipping</p> <p>B/DIP A hole depth entered during backfilling</p> <p>C/DIP A hole depth entered during charging</p> <p> An anomaly has been noted on the hole</p> <p> Hole is loaded outside mass or length tolerance, or the quantity differs</p> <p> Hole is not stemmed / is stemmed out of tolerance, or the top explosive deck is out of tolerance</p> <p> Hole or deck has a comment entered</p> <p>Av Average in-hole density of the bulk explosive</p> <p>OCD Open Cup Density of the bulk explosive</p>
--	---

## 10.3 Entering dip data to update charge plans

You can update or recalculate your charge plan by entering the new **Dip**, **Water**, and **Wet sides** values. Follow these steps to enter new dip data in your charge plan:

1. Delete all loaded decks in a hole.

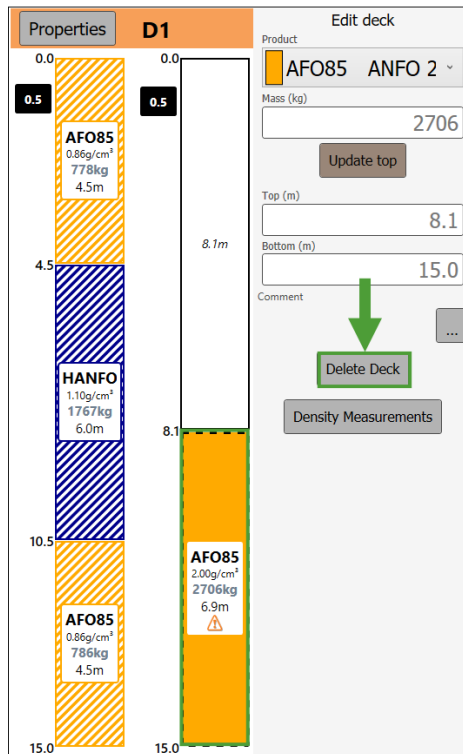

Figure 10-12 Selecting hole's loaded deck to delete it

2. Delete the primer assigned to the deck.

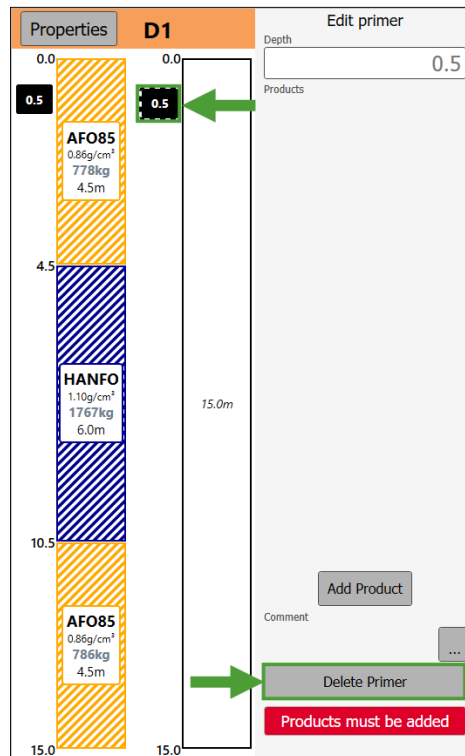

Figure 10-13 Selecting a primer to delete it

3. Enter the new dip parameters.

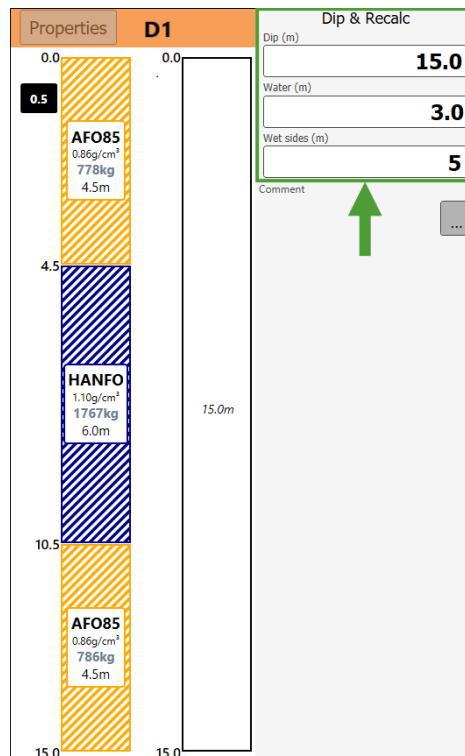

Figure 10-14 Entering new dip parameters

- Click on the loaded deck and add the blast product from the drop-down.

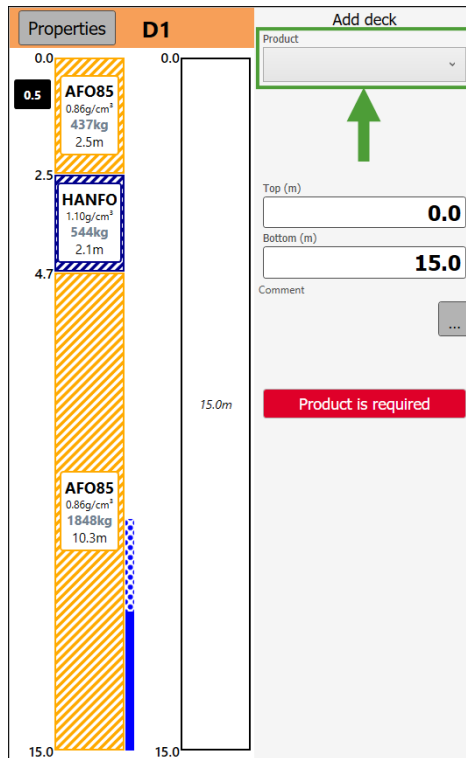

Figure 10-15 Selecting a blast product to be added to the loaded deck

- Specify the mass and the depth of the deck by entering the **Top** and **Bottom** boundaries.

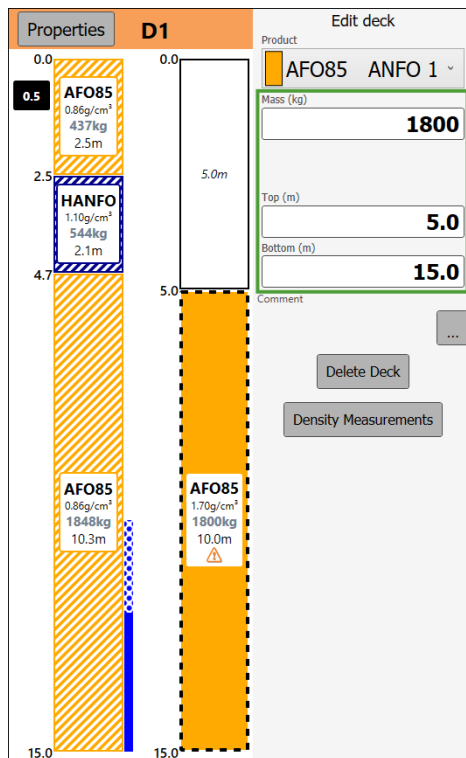

Figure 10-16 Defining the mass and depth of the deck

- Specify the primer by tapping on it in the **Planned** decks. The primer will be copied to the **Loaded** decks, where you will be able to enter its depth and change the used product by tapping on the **Products** field.

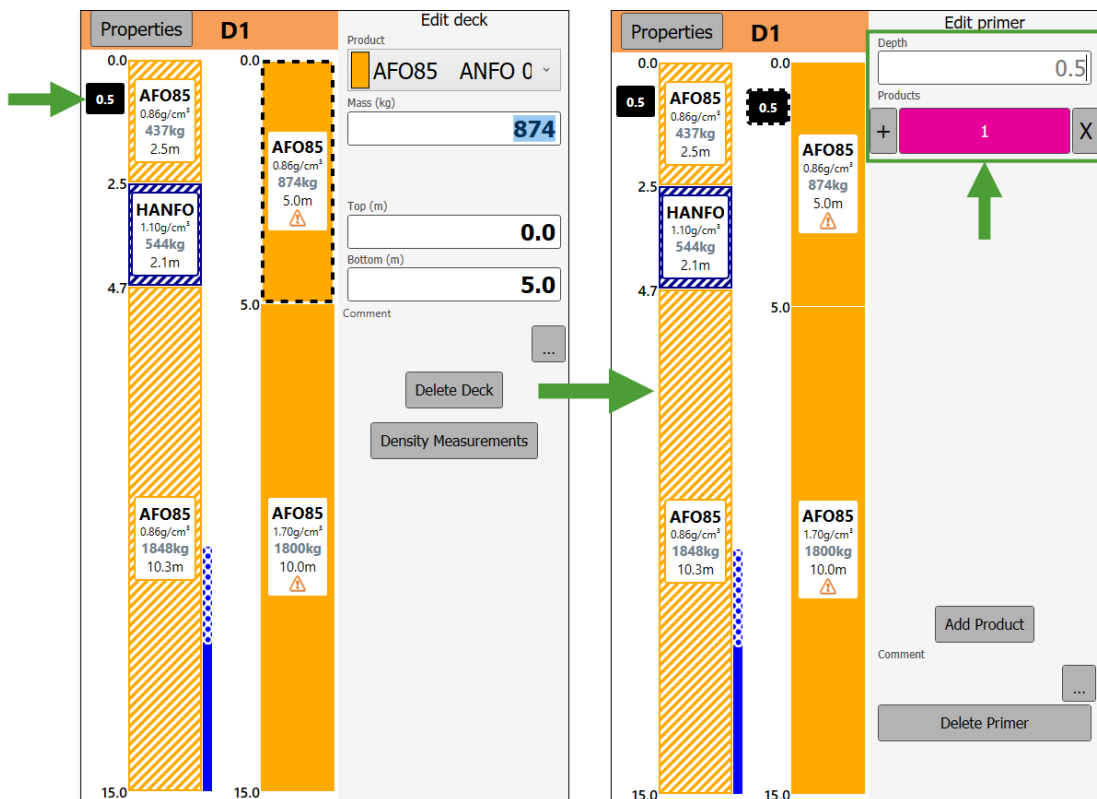

Figure 10-17 Copying the primer to the **Loaded** decks and specifying its properties

## 10.4 Loading decks from the plan

The data in the planned decks cannot be edited, but you can add a deck to the loaded decks based on the planned deck's depth. Namely, when you tap on one of the lower planned decks and tap **Add deck**, a new deck will be added among loaded decks. The newly added deck will be positioned on the same depth as the tapped planned deck.

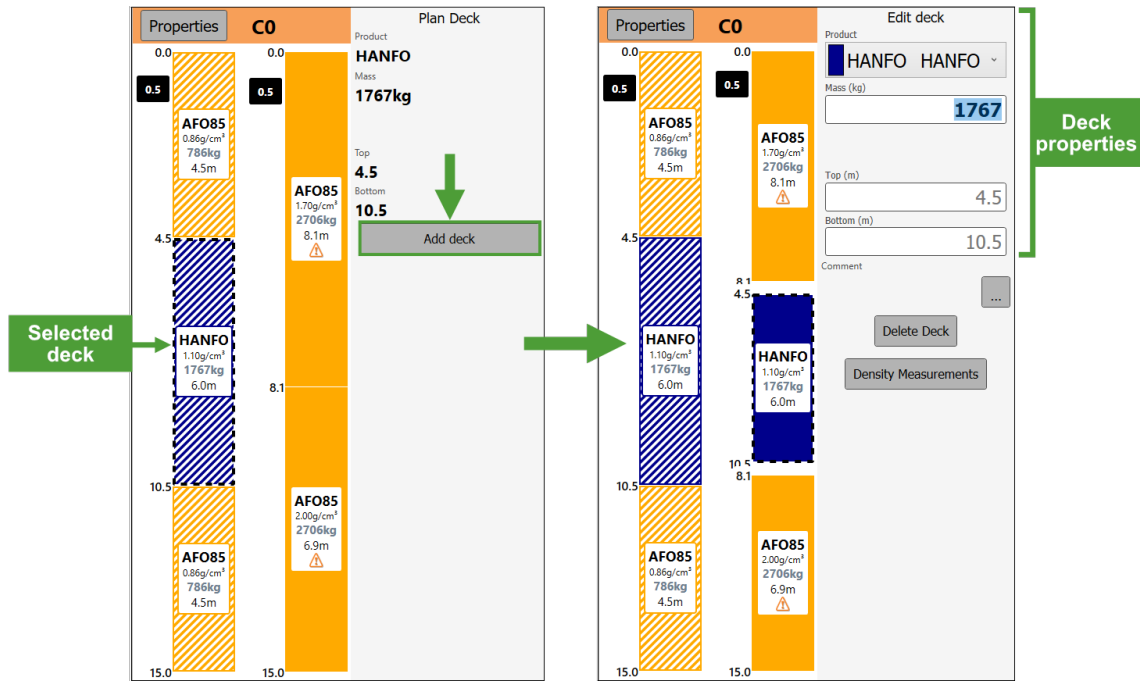

Figure 10-18 Adding a loaded deck from the Planned decks

To configure deck properties, proceed as follows:

1. Select the blast product from the **Product** drop-down menu.
2. Enter the mass of the blast product.

**Note**  
When the mass of a loaded deck is different from plan, the **Update mass** button will flash as a reminder to update the mass of the blast product in the deck.

**Note**  
If the mass you enter is outside the mass tolerance, a warning will be shown. BlastLogic will prompt you to confirm the value when you move to another hole.

3. Adjust the depth of the deck by entering the **Top** and **Bottom** depth values.

- Tap the primer to change its attributes. You can enter its depth and change the product used by tapping on the **Products** field.

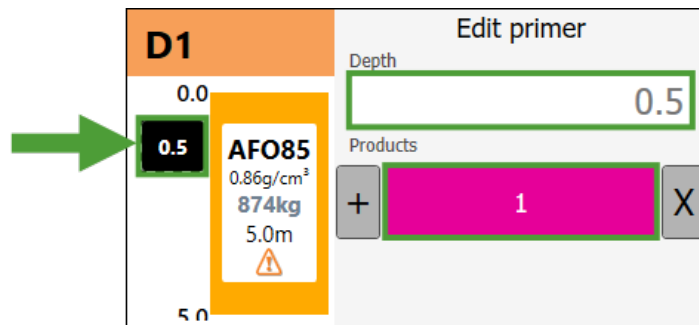

Figure 10-19 Changing primer's attributes

- ▶ To remove a deck, tap it in your view and tap **Delete Deck**.

**Note:** Only loaded decks can be removed.

- ▶ Tap **Density Measurements** to go to the **Open Cup** view where you can enter density data for the holes.

## 10.5 Entering a top-up deck

When the loading truck runs out of product part way through loading a deck, it will return to the hole later to top up. Select a planned deck and then tap the **Top-up deck** button to top up the deck.

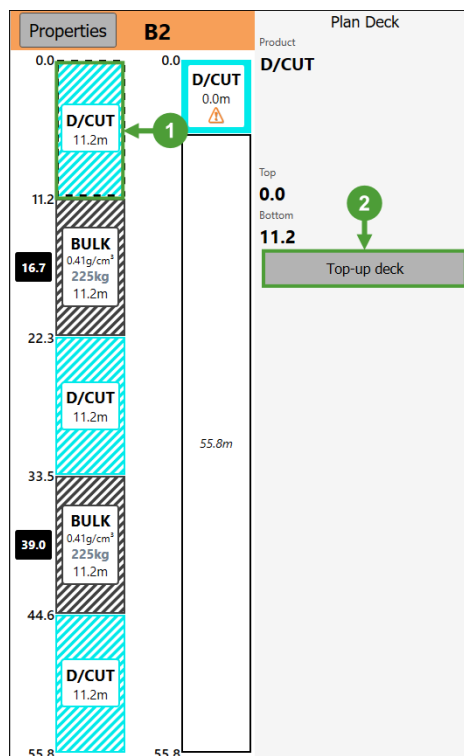

Figure 10-20 Selecting a planned deck to top up the loaded deck

A top-up deck will be loaded to match the mass and top of the plan deck.

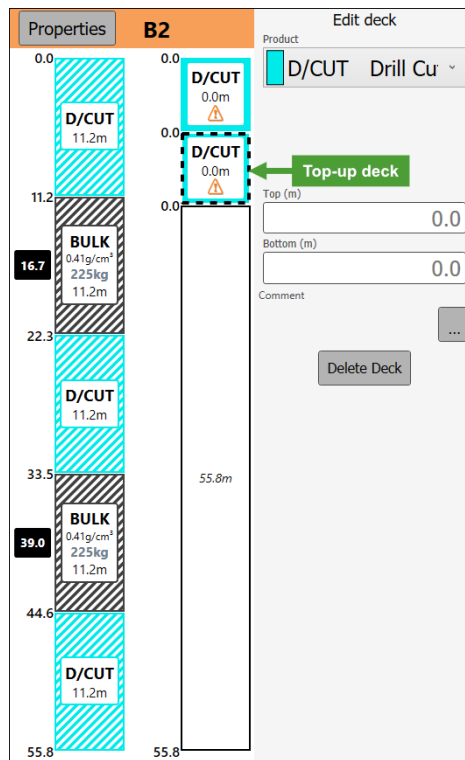

Figure 10-21 Added top-up deck

## 10.6 Loading ad hoc decks

When the condition of a hole has changed since the charge plan was generated, the hole may be loaded differently from the plan. You can load ad hoc decks by selecting a blank deck in the loaded hole, and then manually setting product, top, bottom, and mass.

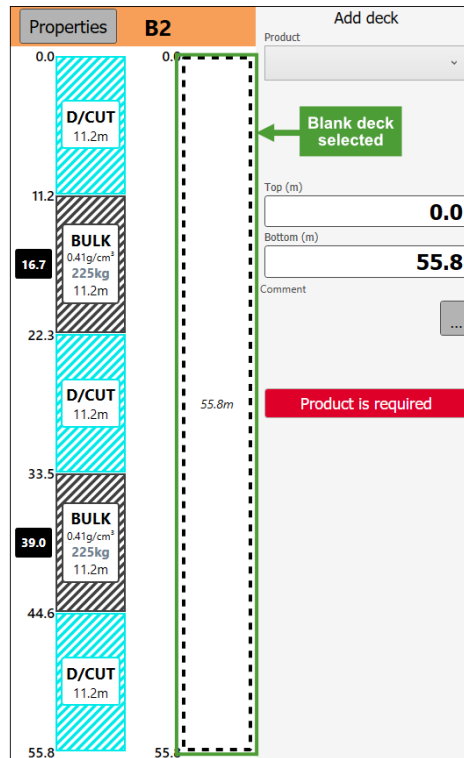

Figure 10-22 Defining attributes for an empty deck



Figure 10-23 New loaded decks specified

## 10.7 Loading ad hoc primers

When the condition of a hole has changed since the charge plan was generated, you can load the hole differently from plan. To load a new primer, tap a primer in the planned decks. The primer you have selected will be loaded to the loaded decks. Change its properties by entering a new depth and product.

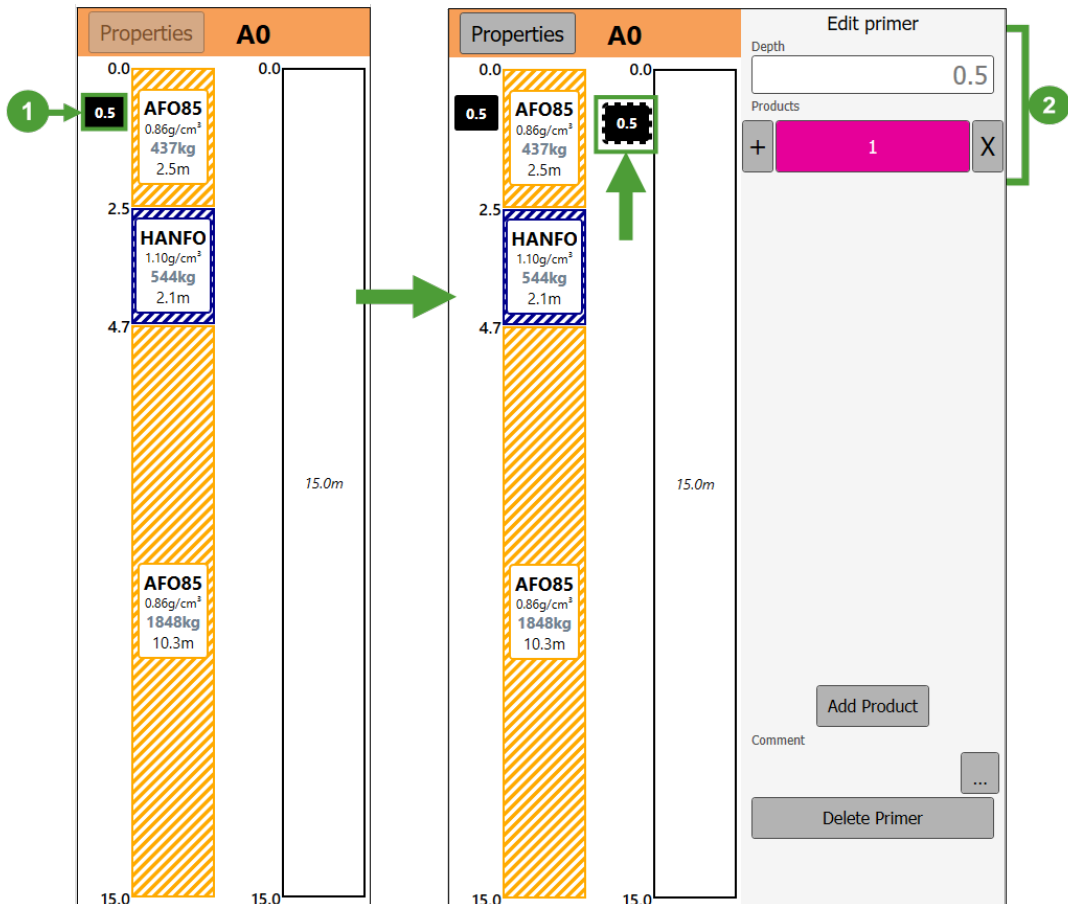
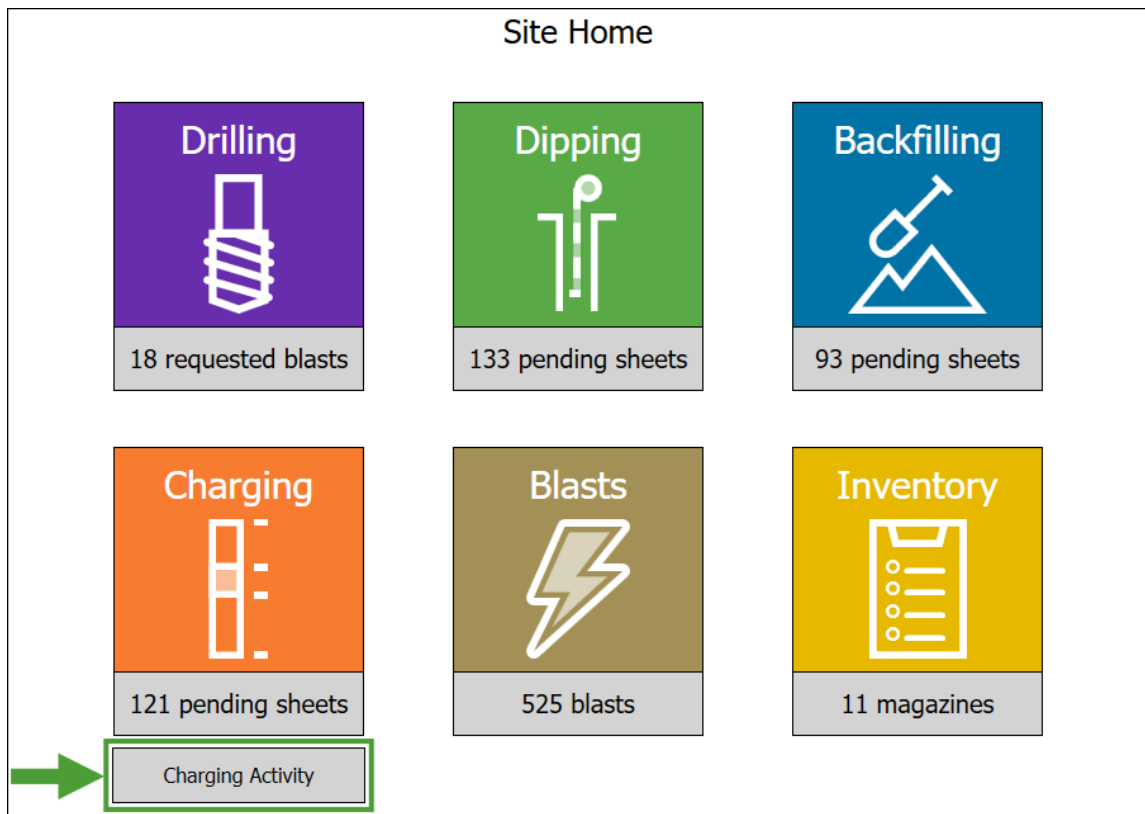

Figure 10-24 Loading a primer from the plan to change its properties for the loaded decks

# 11. Viewing Charging Activity

## 11.1 Viewing charging activity

To view the charging activity, go to the **Site Home** page and tap **Charging Activity**.



**Figure 11-1** Entering the **Charging Activity** module from the **Site Home** screen

The **Charging Activity** screen allows you to filter all recent charging activities using the following drop-downs:

- **Charging Shift**
- **Product**
- **Truck**
- **Loading Truck Operator**
- **Blast**

The filtered charging activity data will be shown in the following tabs:

- **Charging Summary**
- **Decks**
- **Initiating Explosives**

## 11.1.1 Charging Summary tab

The **Charging Summary** tab shows the general information on the decks and products applied in holes, based on the filters you have applied.

The screenshot shows the 'Charging Activity' window with the 'Charging Summary' tab selected. The 'Decks (40)' and 'Initiating Explosives (22)' sub-tabs are also visible. The 'Charging Summary' table shows data for Drill Cuttings, Dummy Product 1.11, and a SUMMARY row. The 'Primer Product' table shows data for Electnet 12.00m, Electnet 16.00m, Electnet 25.00m, and a SUMMARY row. A license expiration notice is visible at the bottom.

Deck Product	Holes	Decks	Mass	Quantity
Drill Cuttings	10	20		
Dummy Product 1.11	10	20	-1280	
SUMMARY	10	40	-1280	

Primer Product	Quantity	Holes
Electnet 12.00m	11	11
Electnet 16.00m	10	10
Electnet 25.00m	1	1
SUMMARY		11

Licence expires in 7 days

Figure 11-2 Information displayed in the **Charging Summary** tab (example)

## 11.1.2 Decks tab

The **Decks** tab shows detailed information recorded for each hole in the blast, based on the filters you have applied.

Blast	Truck	Hole	Time	Product	Mass
HDR_charging_testing_1		A0	7/09/2022 6:00 AM	ANFO 0.86	648
HDR_charging_testing_1		A0	7/09/2022 6:00 AM	Air	
HDR_charging_testing_1		A0	7/09/2022 6:00 AM	ANFO 0.86	648
HDR_charging_testing_1		A0	7/09/2022 6:00 AM	Air	
HDR_charging_testing_1		A1	7/09/2022 6:00 AM	ANFO 0.86	648
HDR_charging_testing_1		A1	7/09/2022 6:00 AM	Air	
HDR_charging_testing_1		A1	7/09/2022 6:00 AM	ANFO 0.86	648
HDR_charging_testing_1		A1	7/09/2022 6:00 AM	Air	
HDR_charging_testing_1		A2	7/09/2022 6:00 AM	ANFO 0.86	648
HDR_charging_testing_1		A2	7/09/2022 6:00 AM	Air	
HDR_charging_testing_1		A2	7/09/2022 6:00 AM	ANFO 0.86	648
HDR_charging_testing_1		A2	7/09/2022 6:00 AM	Air	
HDR_charging_testing_1		A3	7/09/2022 6:00 AM	ANFO 0.86	648
HDR_charging_testing_1		A3	7/09/2022 6:00 AM	Air	
HDR_charging_testing_1		A3	7/09/2022 6:00 AM	ANFO 0.86	648
HDR_charging_testing_1		A3	7/09/2022 6:00 AM	Air	
HDR_charging_testing_1		A4	7/09/2022 6:00 AM	ANFO 0.86	648
HDR_charging_testing_1		A4	7/09/2022 6:00 AM	Air	

Figure 11-3 Information displayed in the Decks tab (example)

### 11.1.3 Initiating Explosives tab

The initiating explosives, also referred to as primary explosives, are explosive materials used in small quantities to ignite a secondary or main explosive charge. These initiators are used in detonators and primers.

The **Initiating Explosives** tab, based on the filters you set, shows in which blasts, holes, and at what depths these primary explosives have been applied.

Blast	Hole Depth	Date and Time
HDR_charging_testing_1	C1	7/09/2022 6:00 AM
HDR_charging_testing_1	C1	7/09/2022 6:00 AM
HDR_charging_testing_1	C2	7/09/2022 6:00 AM
HDR_charging_testing_1	C2	7/09/2022 6:00 AM
HDR_charging_testing_1	C3	7/09/2022 6:00 AM
HDR_charging_testing_1	C3	7/09/2022 6:00 AM

Figure 11-4 Information displayed in the Initiating Explosives tab (example)

# 12. Blasts |

The **Blasts** module provides summarised information on the blast and its holes based on the data you have input in other BlastLogic Tablet modules.

## 12.1 Getting started

To load the **Blasts** module, go to the **Site Home** page and tap the **Blasts** button.

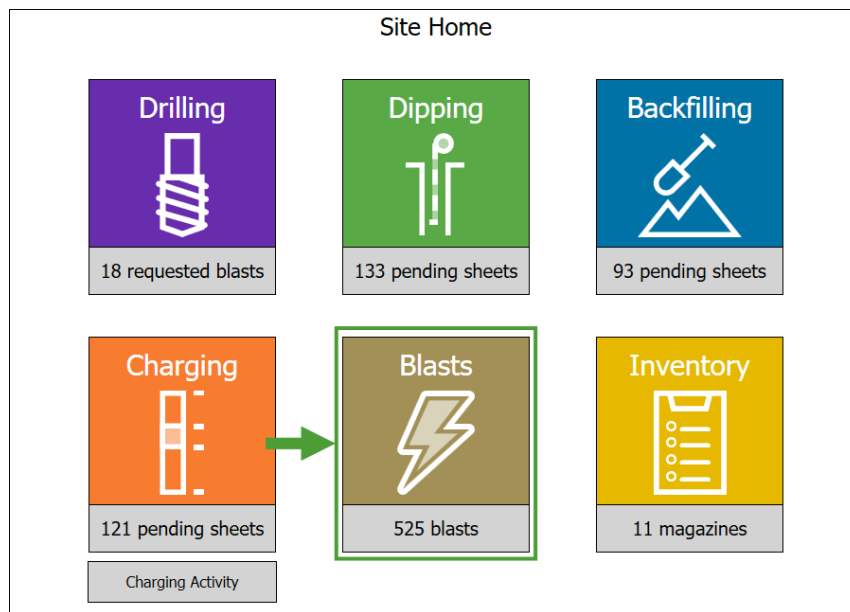
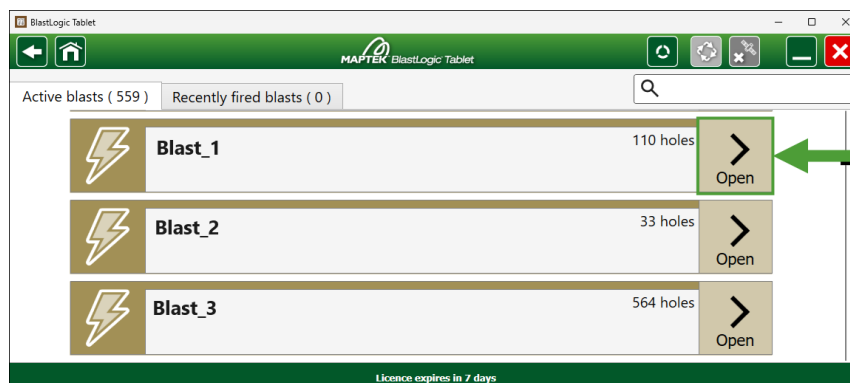

**Figure 12-1** Entering the **Blasts** module from the **Site Home** screen

A list of blasts saved in your database will appear. The blasts will be grouped into the following tabs:

- **Active blasts**
- **Recently fired blasts**

Navigate to the blast that you want to view and tap **Open**.



**Figure 12-2** Selecting a blast to open in the **Blasts** module

**Tip**

Use the search field to filter the list of displayed blasts. As you enter the characters constituting the required phrase into the search field, the BlastLogic Tablet will dynamically show the blasts that include matches, even if your phrase is part of a longer word.

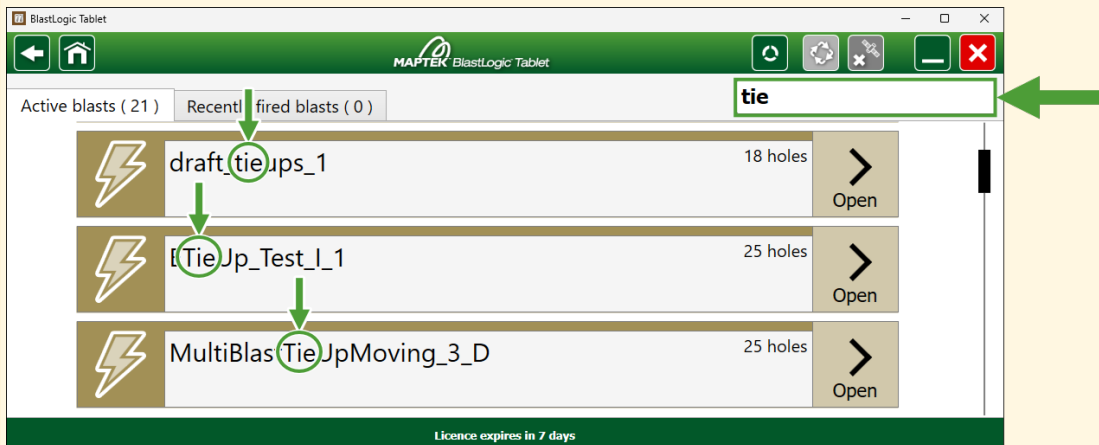



Figure 12-3 Using the search field to navigate to the required blast

## 12.2 Hole status in Blasts module

The status of each hole in your view is indicated by an icon.

You can check the meaning of each icon on the pop-up window that appears when you tap the  button on your task bar.

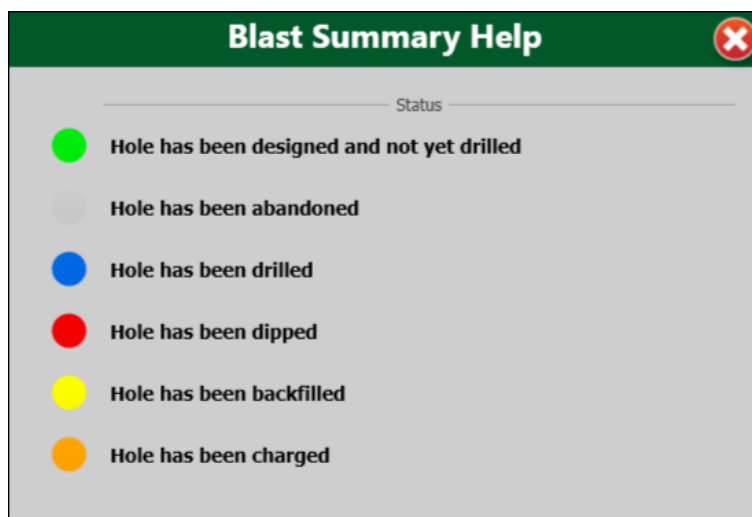

Figure 12-4 Hole status in the Blasts module

## 12.3 Summary view

The screenshot displays the 'Summary' view of a blast operation. It features a top navigation bar with 'Server Name' and 'MAFTER BlastLogic Tablet'. Below this, the 'Blast Name' is shown. The main content area is divided into four sections, each highlighted with a green callout box:

- Hole status information:** A table showing the total number of holes in various states: 14 total, 3 drilled, 10 dipped, 5 backfilled, 0 AdHoc, 1 abandoned, and 1 redrilled.
- Planned and actual hole charging:** A table comparing planned vs actual counts: 14 planned vs 12 actual total holes, 0 vs 5 without primers, and 4 vs 1 requiring stemming.
- Blast Products Report:** A table with columns for Planned, Loaded, Difference, and From Inventory. It lists products like Down Hole Detonators, Bulk Explosives, and Stemming.
- Custom View Hole Counts:** A table with columns for Description and Total, listing sampling requirements like 'Needs to be sampled' (0), 'Is hazardous, do not sample' (0), and 'No further action needed' (0).

Figure 12-5 Information displayed in the Summary view (example)

The **Summary** view in **Blasts** module screen is composed of four main components:

- The table with hole status information
- The table with planned and actual hole charging (comparison)
- The table listing the applied blast products
- The table with the custom view hole counts

### 12.3.1 Hole status information

The table summarises the hole information entered in other Tablet modules (**Drilling**, **Dipping**, **Backfilling**, and **Charging**) in a table form.

Total number of holes	14
Total number of drilled holes	3
Total number of dipped holes	10
Total number of backfilled holes	5
Total number of AdHoc holes	0
Total number of abandoned holes	1
Total number of redrilled holes	1

Figure 12-6 Hole status information table (example)

### 12.3.2 Planned and actual hole charging

The table compares the planned and actual charging based on the loaded holes, primer application, and holes requiring stemming.

	Planned	Actual
Total number of holes to be loaded	14	15
Total number of holes without a primer	0	5
Total number of holes requiring stemming	4	1

Figure 12-7 Planned and actual hole charging comparison (example)

### 12.3.3 Blast Products Report

The **Blast Products Report** table aggregates information on the planned and applied blast products, based on the information you enter in other Tablet modules.

	Planned	Loaded	Difference	From Inventory
▼ Down Hole Detonators	12	3	9	0
▼ Electnet	12	3	9	0
Electnet 12.00m	4	3	1	0
Electnet 16.00m	8	0	8	0
▼ Bulk Explosives	37,392 kg	26,091 kg	11,301 kg	0
▼ ANFO	22,846 kg	20,790 kg	2,056 kg	0
ANFO 0.86	22,846 kg	4,828 kg	18,018 kg	0
ANFO 1.70	0 kg	10,546 kg	-10,546 kg	0
ANFO 2.00	0 kg	5,416 kg	-5,416 kg	0
HANFO 1.10	14,546 kg	5,301 kg	9,245 kg	0

Figure 12-8 Blast Products Report (example)

### 12.3.4 Custom View Hole Counts

The categories listed in the **Custom View Hole Counts** table correspond to the categories you have added in the BlastLogic Desktop application (**Home** ribbon > **Setup** group >  **Site** > **Tablet hole display rules**).

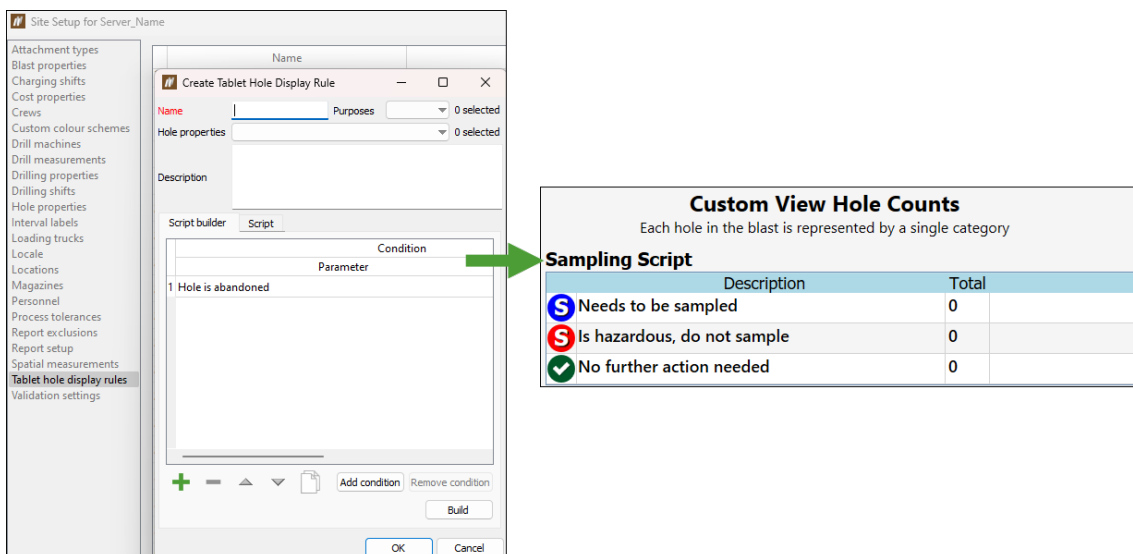



Description	Total
 Needs to be sampled	0
 Is hazardous, do not sample	0
 No further action needed	0

Figure 12-9 Custom View Hole Counts table based on the Tablet hole display rules defined in the BlastLogic Desktop application

## 12.4 Blast status

The **Status** tab in the **Blasts** module allows you to change the status of a blast to **Fired**, and specify the fired time.



Figure 12-10 The **Status** tab in **Blasts** module

### 12.4.1 Marking a blast as fired

Follow these steps to mark the required blast as fired:

1. Open the **Status** tab.
2. Select the required shotfirer and enter the pin to log in.

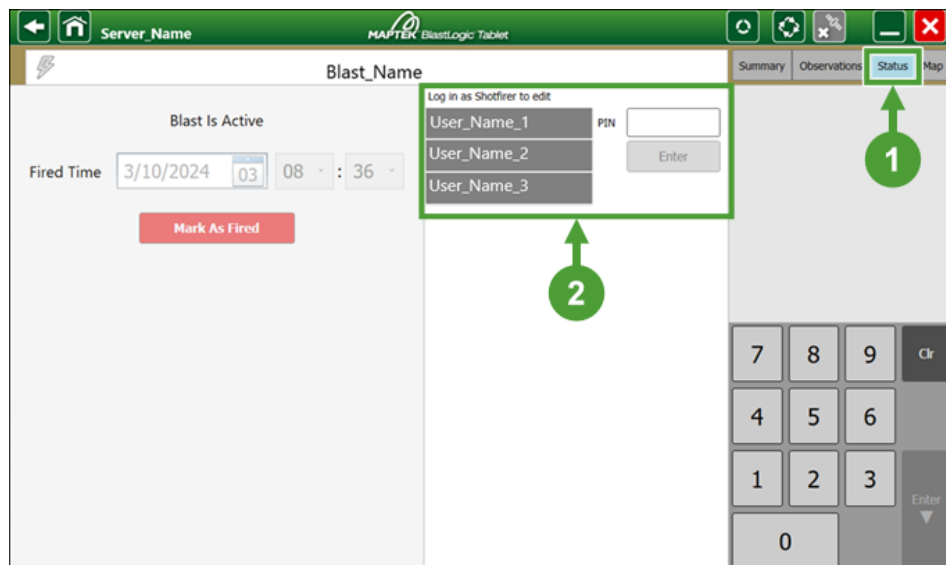

Figure 12-11 Entering the **Status** tab in **Blasts** module and logging in as a shotfirer

**Note:** Only personnel with **Shotfirer** permissions can mark blasts as fired. To manage site personnel and permissions assigned to them, open the BlastLogic Desktop application, go to the **Home** ribbon > **Setup** group > **Site** and select **Personnel**.

3. Specify the date and time of firing the blast.

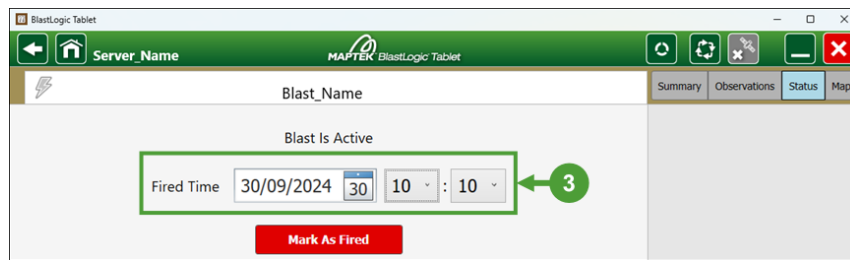

Figure 12-12 Setting the date and time of firing the blast

4. Tap **Mark As Fired**. The date and time of firing the blast that you have set will be displayed.

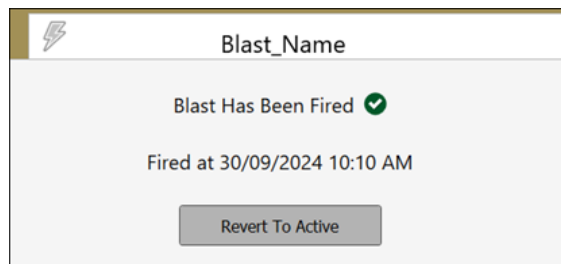

Figure 12-13 The saved date and time of firing the blast

The blast will be moved to the **Recently fired blasts** list in the **Blasts** module.

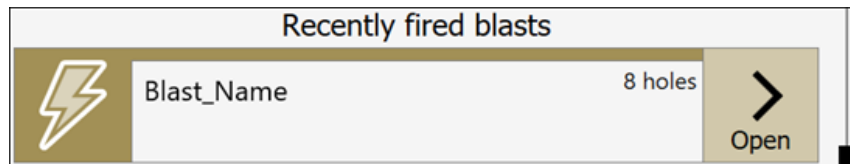

Figure 12-14 Recently fired blasts list

## 12.4.2 Reverting a blast to active state

Once you mark a blast as fired, you cannot edit its date and time of firing. However, you can change this data by marking the blast as active again. To do so, you need to log in as a shotfirer in the **Status** tab (see 12.4.1 [Marking a blast as fired](#) on the previous page for details). After logging in, tap the **Revert to Active** button. The blast will become active again, which will allow you to apply the revised date and time of firing.

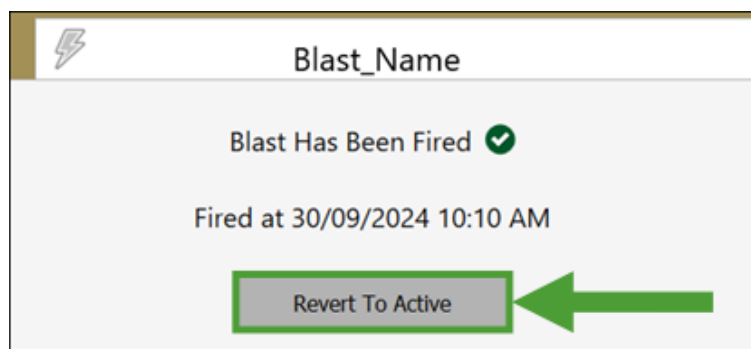

Figure 12-15 The **Revert to Active** button

**Note:** After one week, the fired blasts are removed from the BlastLogic Tablet, so make sure you apply the required changes within this period.

## 12.5 Map view

The **Map** view visualises the location of holes in your blast. Using the drop-down, you can choose the view in which you want the holes to be displayed.

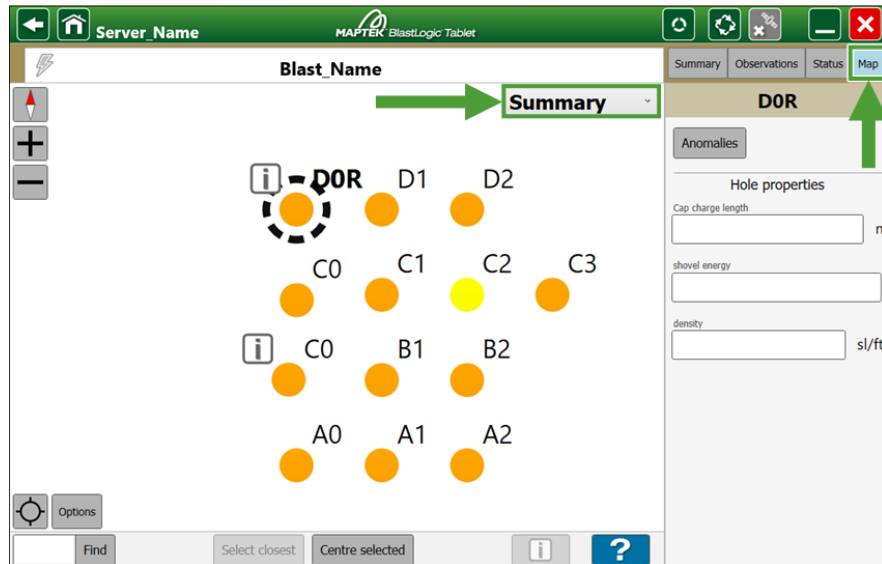

Figure 12-16 The Map view in Blasts module

You can record anomalies for each hole in your blast by tapping the **Anomalies** button. See [6.4 Entering and viewing anomalies](#) on page 21 for details.

**Note:** The **Hole properties** shown in the **Map** view in **Blasts** module correspond to the identifiers you have set in the **Hole properties** panel in the BlastLogic Desktop application (**Home** ribbon > **Setup** group > **Site** > **Hole properties**).

# 13. Inventory Data |

The **Inventory** module allows you to view the stock levels of blast products, their inflow and outflow in the storage facilities, as well as edit inventory levels and bulk usage.

## 13.1 Inventory data

To load the **Inventory** module, go to the **Site Home** page and tap the **Inventory** button.

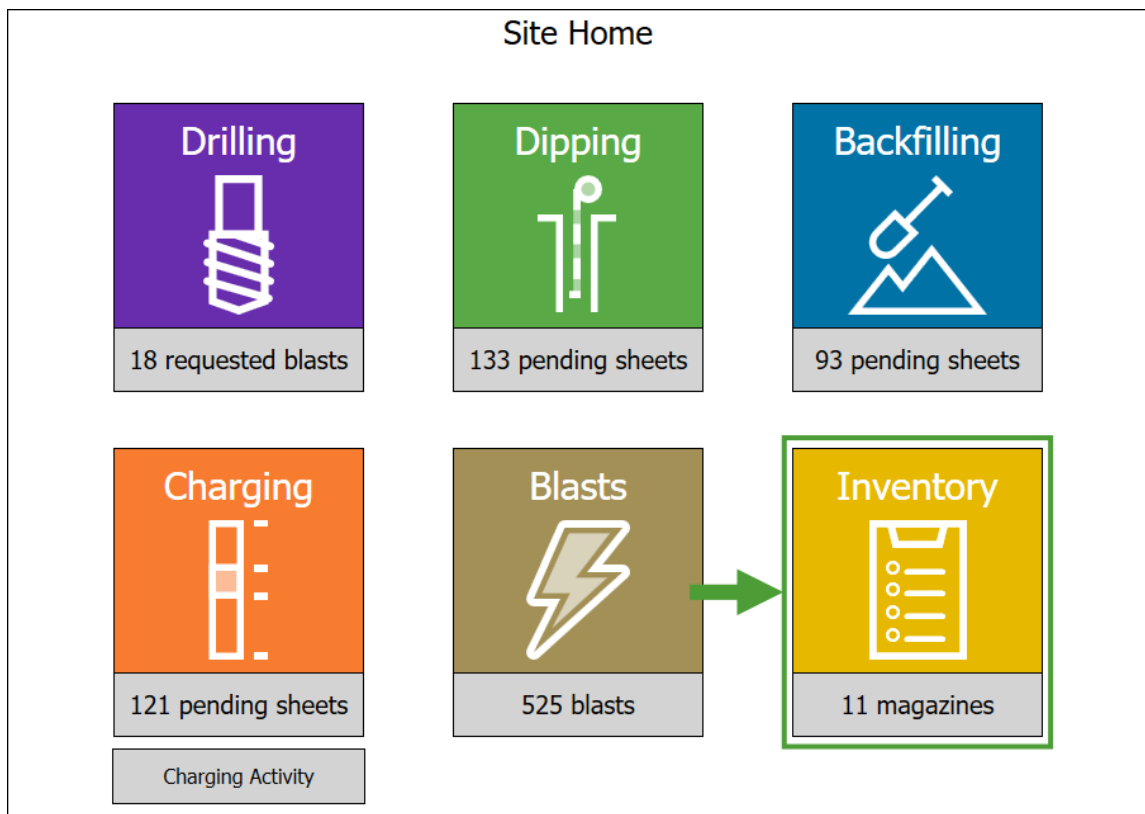

**Figure 13-1** Entering the **Inventory** module from the **Site Home** screen

The **Inventory** module consists of four tabs:

- **Stock Levels**
- **History**
- **Edit Inventory**
- **Bulk Usage**

### 13.1.1 Stock Levels

Use the **Stock Levels** tab to check the location, quantity, and the last stocktake of the stocked blast products and equipment. You can filter the view by selecting the required items from the **Magazine**, **Product Type**, and **Product** drop-down menus.

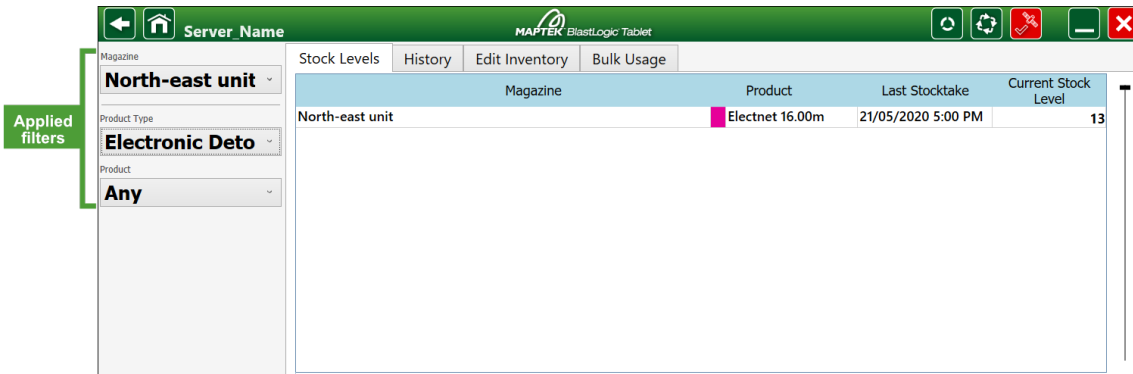

Figure 13-2 Applying filters in the **Stock Levels** tab (example)

### 13.1.2 History

Use the **History** tab to track the inflow and outflow of blast products and equipment in the storage facilities. You can filter the view by specifying the time frame and selecting the required items from the **Source**, **Product Type**, **Product**, **Stock Keeper**, and **Blast** drop-down menus.

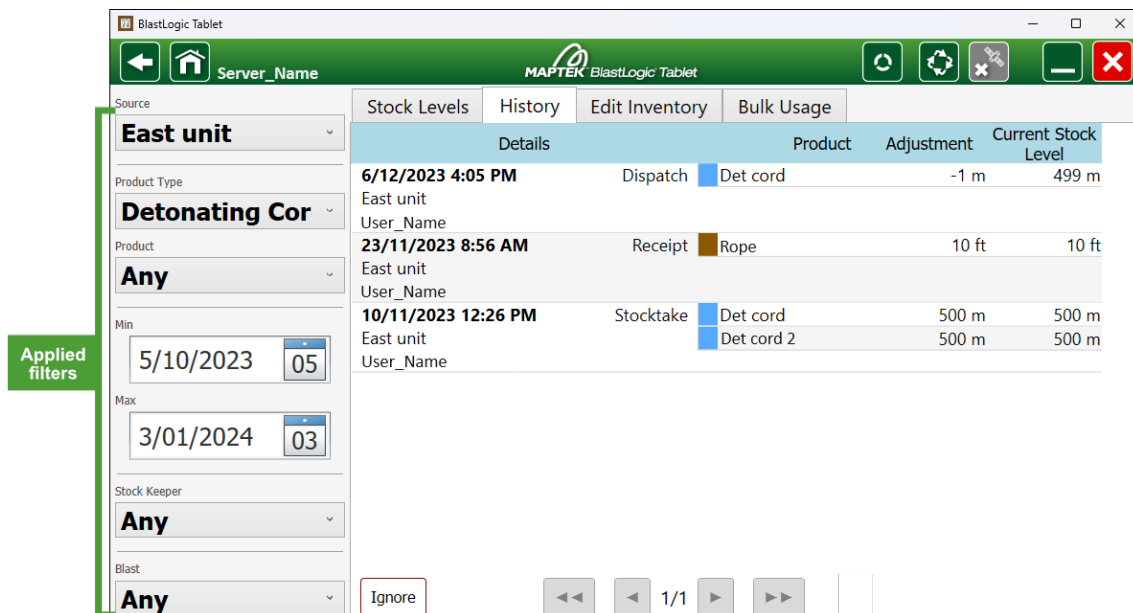





Figure 13-3 Applying filters in the **History** tab (example)

The **Ignore** button allows you to ignore the entries in the history. Tap it to enter the history entry selection screen.

**Note:** The **Ignore** button will be enabled once you have logged into the **Edit Inventory** tab or the **Bulk Usage** tab.

Stock Levels	History	Edit Inventory	Bulk Usage		
Details		Product		Adjustment	Current Stock Level
	<b>6/12/2023 4:05 PM</b>	Dispatch	Det cord	-1 m	499 m
	East unit				
	User_Name				
	<b>23/11/2023 8:56 AM</b>	Receipt	Rope	10 ft	10 ft
	East unit				
	User_Name				
	<b>10/11/2023 12:26 PM</b>	Stocktake	Det cord	500 m	500 m
	East unit		Det cord 2	500 m	500 m
	User_Name				















Done   1/1  

Figure 13-4 The screen that allows you to select an entry to be ignored

- Tap the  button to select an entry to be ignored. When the  button is tapped, it will change to  and the entry will be struck through. Confirm your selection by tapping **Done** or cancel your selection by tapping .

Stock Levels	History	Edit Inventory	Bulk Usage		
Details		Product		Adjustment	Current Stock Level
	<b>6/12/2023 4:05 PM</b>	Dispatch	Det cord	-1 m	499 m
	East unit				
	User_Name				
	<b>23/11/2023 8:56 AM</b>	Receipt	Rope	10 ft	10 ft
	East unit				
	User_Name				
	<b>10/11/2023 12:26 PM</b>	Stocktake	Det cord	500 m	500 m
	East unit		Det cord 2	500 m	500 m
	User_Name				

Done   1/1  



Selected entry  Tap to confirm your selection.

Figure 13-5 The screen where an entry to be ignored is selected

- To restore a previously ignored product, tap the **Ignore** button in the **Inventory** module's **History** tab, and then tap the  button next to the entry that you wish to restore. Confirm by tapping **Done**.

The ignored product entries are treated as though they were never made, and consequently, they do not affect the product stock levels. The listed products are not deleted from the history; they remain visible, but are struck through to indicate that their effect has been ignored.

### 13.1.3 Edit Inventory

Use the **Edit Inventory** tab to update the inflow and outflow of blast products and equipment in the storage facilities. The inventory data that you enter will be uploaded to the BlastLogic Server.

To edit inventory information, select the stock keeper from the list and enter the assigned PIN. You can set the PIN in the BlastLogic Desktop application (**Home** ribbon > **Setup** group >  **Site > Personnel**).

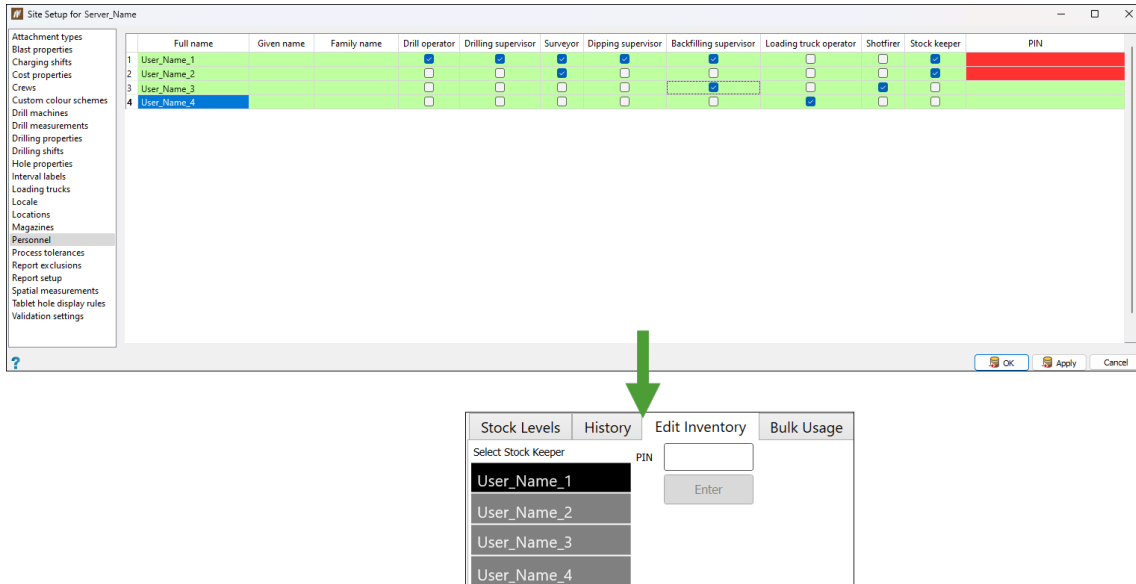



**Figure 13-6** The PIN set in the BlastLogic Desktop application used as login credentials in the Tablet's **Edit Inventory** tab

Once you have logged in to the **Edit Inventory** panel, you can add product and equipment entries to update the inventory status.

Follow these steps to add an entry to your inventory:

1. Select a blast product or equipment type from the **Product** drop-down list.
2. Select the required product name from the list.
3. Select the product status (**Received**, **Dispatch**, **Check In**, **Check Out**, or **Stocktake**).
4. Select the storage facility from the **Magazine** drop-down.
5. Set the **Date and Time** of your entry.

 **Tip:** Tap the  button to set the **Start Date** and **Start Time** to the current time.

6. Enter the amount of the product and, optionally, add a comment.
7. Tap **Save** at the bottom of your screen to save the entry.

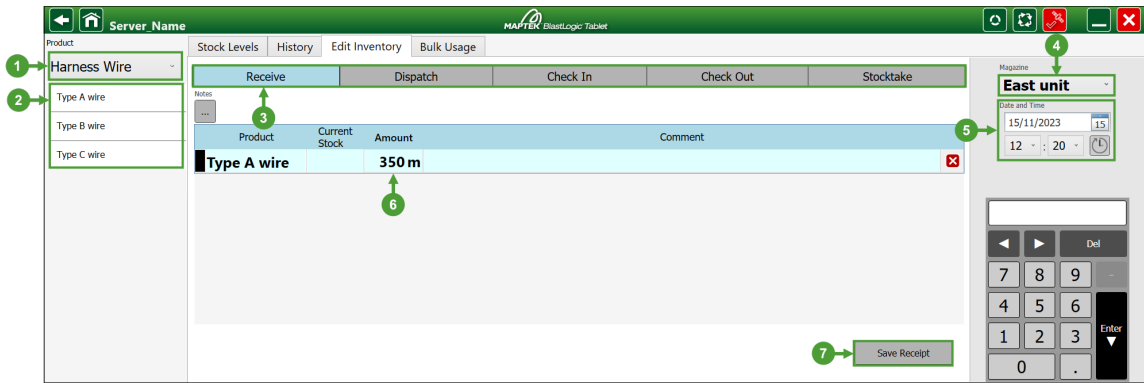

Figure 13-7 Updating inventory status (sequence of steps)

The changes you have made in the **Edit Inventory** tab will be reflected in the **Stock Levels** tab.

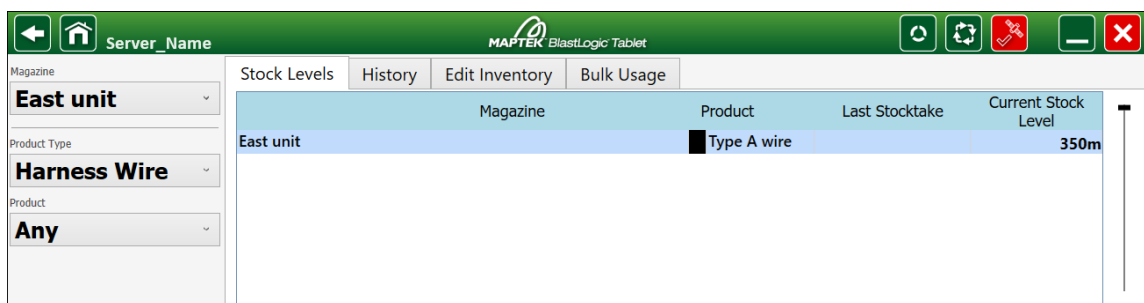

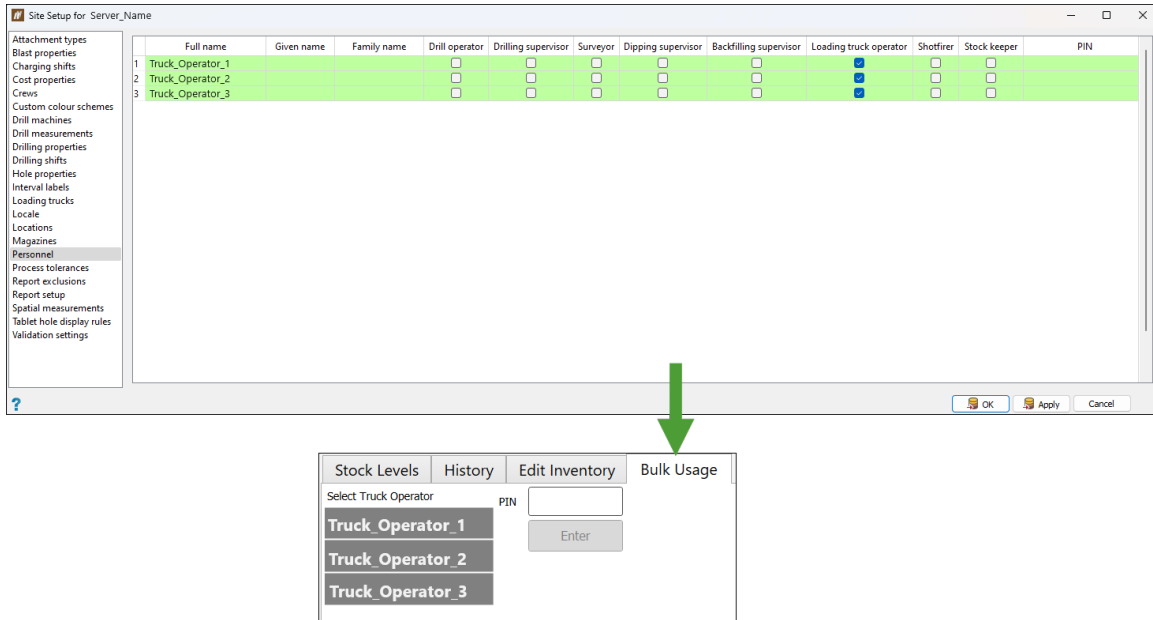

Figure 13-8 Stock levels updated after editing the inventory

## 13.1.4 Bulk Usage

The **Bulk Usage** tab allows you to record the amount of blast products transported by loading trucks for each blast. Access to this tab is limited to the users with truck operator permissions. To enter it, select a truck operator from the list and enter the assigned PIN. You can set the PIN in the BlastLogic Desktop application (**Home** ribbon > **Setup** group >  **Site** > **Personnel**).



**Figure 13-9** The PIN set in the BlastLogic Desktop application used as login credentials in the Tablet's **Bulk Usage** tab

Once you have logged in to the **Bulk Usage** panel, you can select a product to add information on its transport.

Follow these steps to add an entry in the **Bulk Usage** tab:

1. Select a blast product from the **Product** list.
2. Enter the amount of the transported product and, optionally, add a comment.
3. Select the loading truck from the drop-down menu.
4. Select the blast from the drop-down menu.
5. Set the **Date and Time** of your entry.
6. Tap **Save** at the bottom of your screen to save the entry.

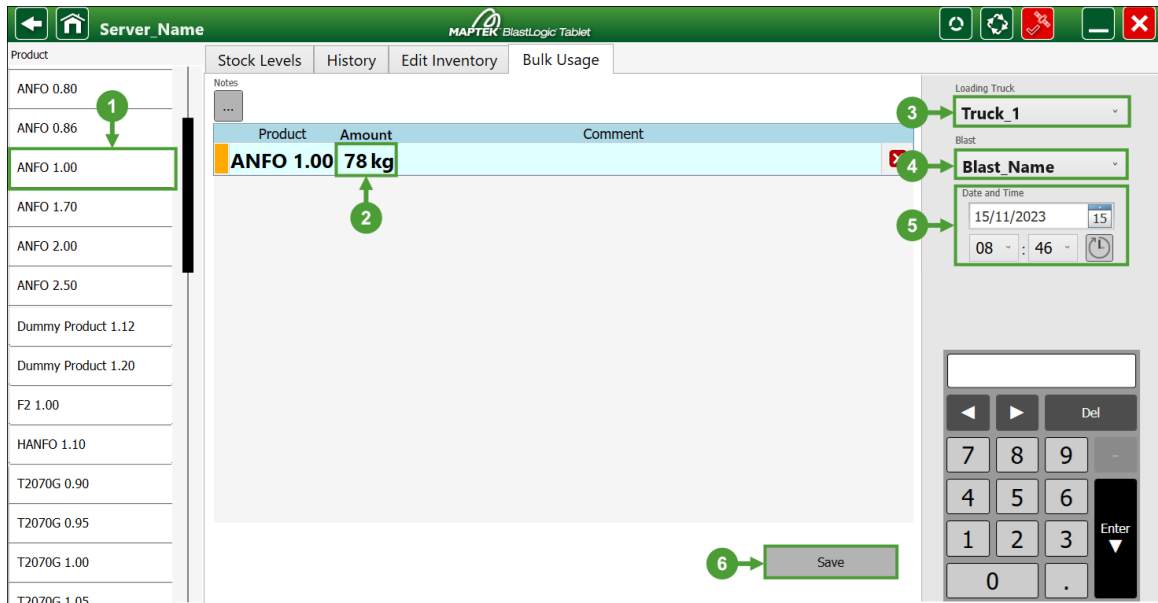

Figure 13-10 Adding an entry in the Bulk Usage tab

The entry will be reflected in the History tab.

Stock Levels	History	Edit Inventory	Bulk Usage
Details			
15/11/2023 8:46 AM		discharge	ANFO 1.00
Truck_1			-78 kg
Blast_Name			
Truck_Operator_1			

Figure 13-11 History entry added

# 14. Editable Parameters and Properties

When using the BlastLogic Tablet, you can edit charge rule parameters to modify the charge plan without using the standard measure inputs (depth, water, wet sides, and temperature).

Use the **Edit charge rule parameters** panel in the BlastLogic Desktop application to set the appropriate charge rule parameter. You can open this panel from an unpublished charge rule (**Charging** ribbon > **Design** group >  **Create Charge Rule** > **Edit parameters...**).

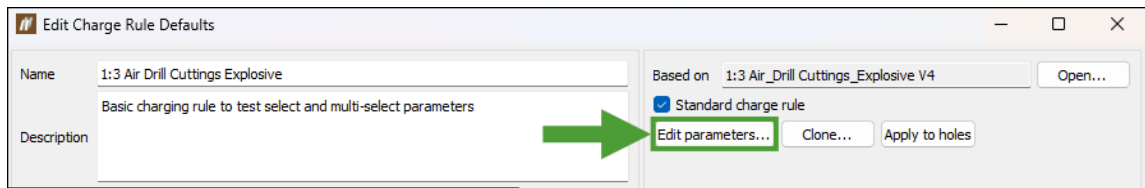



Figure 14-1 The **Edit parameters...** button in the BlastLogic Desktop application

Next, in the **Edit Charge Rule Parameters** window, click  to add a charge rule parameter. Enter the **Identifier**, **Label**, **Description**, **Type**, and select the **Tablet editing** checkbox.

 **Important:** To enable **Tablet editing**, the charge rule parameter must be set as **Boolean** or **Select** type.

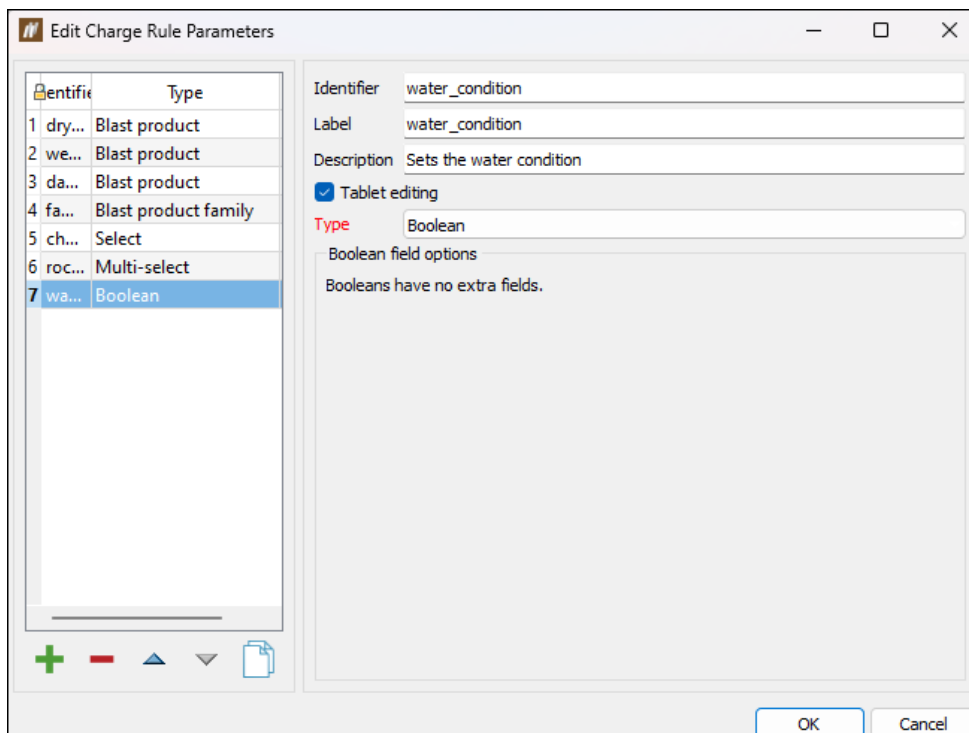
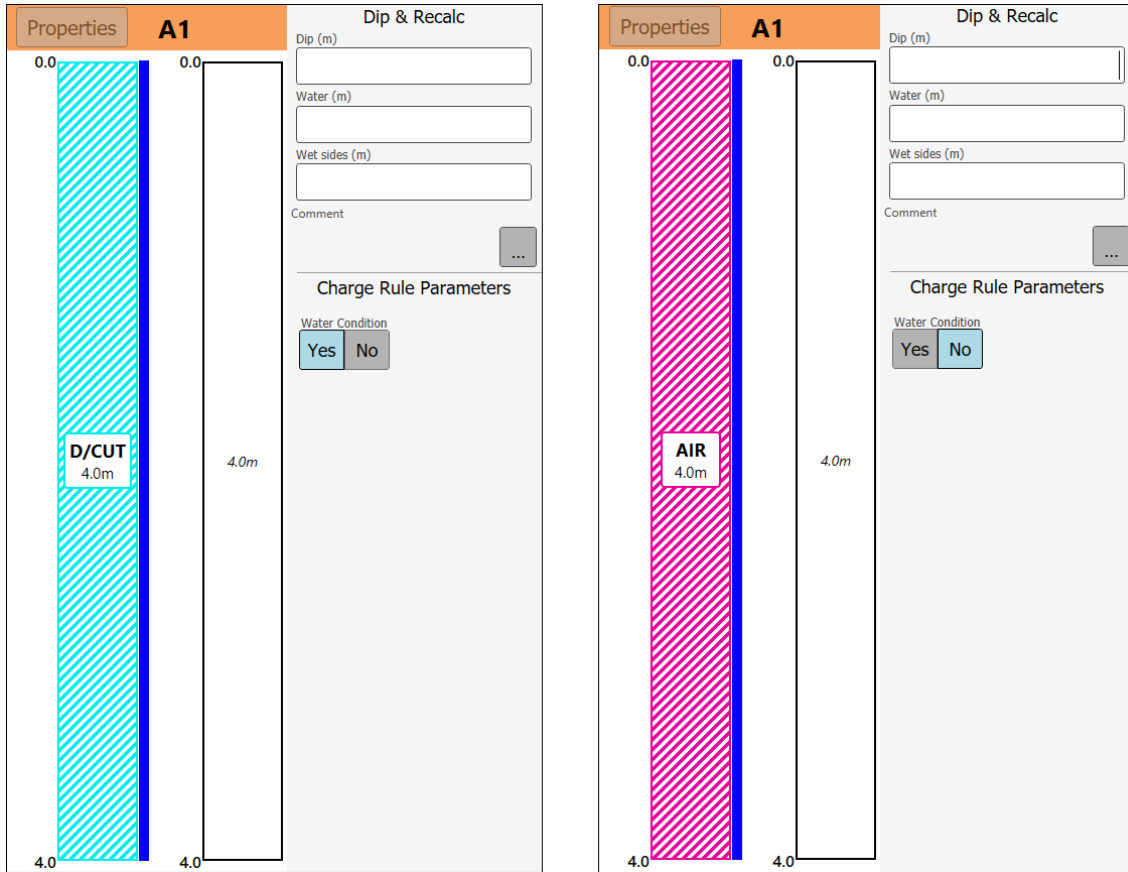

Figure 14-2 Specifying a charge rule parameter that can be edited on the BlastLogic Tablet (example)

The charge rule then needs to be applied to a set of holes in a blast. Once you apply it, you can then modify the charge rule parameter on the Tablet in the **Charging** module's **Preview** tab.

In the example below, you can toggle between the water condition properties by tapping the appropriate condition (**Yes** or **No**), which will update the charge plan.



**Figure 14-3** Updating a charge plan by changing the specified charge rule parameter

Any changes that you make to the charge rule parameter on that hole will be reflected on the Desktop application.

Similarly, you can add custom hole properties on the Desktop application (**Home** ribbon > **Setup** group > **Site** > **Hole properties** panel) and edit them on the Tablet. The additional benefit of this approach is that the data is stored in and can be accessed from OData feeds.

Follow these steps to add a custom hole property on the Desktop application:

1. Go to the **Home** ribbon > **Setup** group > **Site** and select **Hole properties** panel.
2. Click **+** to add a new property.
3. Specify the **Identifier**, **Label**, **Purpose**, and **Type** of the new property. The properties you will have to specify will depend on the **Type** that you select.

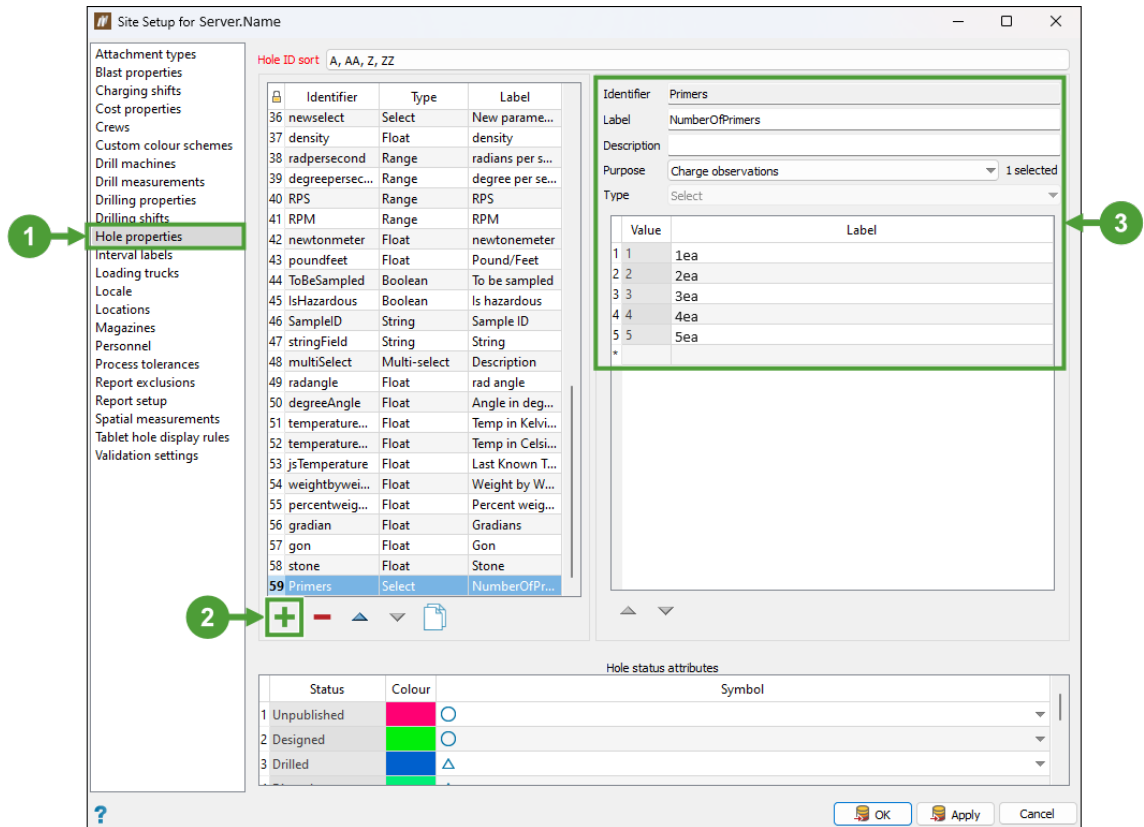

Figure 14-4 Adding a custom hole property in the BlastLogic Desktop application

In the example above, the **Purpose** has been set to **Charge observations**. This property will be displayed in the **Charging** module on the Tablet, as follows:

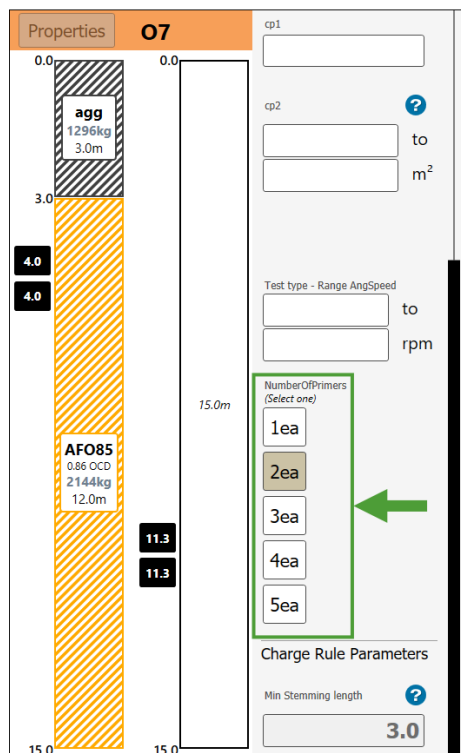

Figure 14-5 Displaying the hole property defined in the BlastLogic Desktop application

# 15. Troubleshooting I

## 15.1 Restoring default screen layout on the BlastLogic Tablet

If your screen layout changes so that the **Map** view becomes displayed on the right side of the screen and **Hole properties** information with the calculator on the left side, you can restore the default view by completing the following steps:

1. Go to any sheet in the **Dip** module.

**Note:** This method cannot be used in the **Drill** module, but drill sheets will display correctly after you complete these troubleshooting steps.

2. On the left side that now displays the calculator and **Hole properties** information, tap anywhere above the calculator and drag the panel to the right side.
3. Your set layout preference will be saved and the calculator and **Hole properties** section will be displayed on the right side on every sheet.

**Note:** This method will not work with mouse pointer, as the Tablet application is set to recognise touchscreen inputs for this functionality.

Alternatively, you can also change the layout by following these steps:

1. Open **Registry Editor** application on your device.
2. In **Registry Editor**, find the folder `Computer\HKEY_CURRENT_USER\Software\Maptek\BlastLogic Tablet`.
3. You should see a key named **Handedness** with the value set to **Left**. Change the **Handedness** value to **Right**.
4. Restart the Tablet application to apply the changes.

## 15.2 Hiding tablet keyboard

If you wish to prevent the tablet on-screen keyboard from appearing, turn off Windows **Tablet mode** in your computer settings.

**Note:** Windows **Tablet mode** is a feature of the Windows 10 OS.